



## ULS-FLW-OCH MODEL

### ULTRASONIC OPEN CHANNEL FLOWMETER TECHNICAL MANUEL



# Contents

<b>Brief Instructions .....</b>	<b>1</b>
<b>1. Display Interface .....</b>	<b>1</b>
<b>2. Buttons .....</b>	<b>1</b>
3. Press (SET) to enter the first level menu .....	1
4. Calibration of "4mA flow value" and "20mA flow value" .....	1
5. Type Selection of Measuring Weirs and Flumes .....	1
5.1 Triangular Weir .....	2
5.2 Rectangular Weir .....	2
5.3 Trapezoidal Weir .....	2
5.4 Parshall Flume .....	2
<b>II. Principles .....</b>	<b>3</b>
1. Principle of Ultrasonic Liquid-level Measurement .....	3
2. Principle of Water Flow Measurement in Measuring Weirs and Flumes .....	3
<b>IV. Installation .....</b>	<b>6</b>
4.1 Shape of Open Channel Flowmeter .....	6
4.2 Probe Installation .....	8
4.3 Site Installation Drawing of Weirs and Flumes for Open Channels .....	12
4.4 Installation of Weirs and Flumes .....	13
4.5 Wiring Diagram .....	15
V. Settings .....	18
5.1 Interface Introduction of Operation Mode .....	18
5.2 Menu Instruction .....	18
5.3 Menu Interface and Operation Instructions .....	18
<b>5.3.2 Description of Level I Menu .....</b>	<b>19</b>
<b>5.3.2.1 "0 End setting" .....</b>	<b>19</b>
<b>1 Instantaneous flow rate alarm mode: .....</b>	<b>22</b>
<b>2 Instantaneous flow rate alarm value: .....</b>	<b>22</b>
<b>3 Return difference of instantaneous flow rate alarm value: .....</b>	<b>22</b>
<b>4 Cumulative flow rate proportional output: .....</b>	<b>22</b>
<b>5 Preset cumulative flow rate: .....</b>	<b>23</b>
5.3.8 "7 Parameter calibration" .....	23
5.3.9 "8 Communications setting" .....	24
5.3.10.1 Triangular weir: .....	24
5.3.10.2 Rectangular weir: .....	25
5.3.10.3 Trapezoidal weir: .....	26
5.3.10.4 Parshall flume: .....	26
5.3.10.5 U-shaped channel .....	27
5.3.10.7 Rectangular channel: .....	30
5.3.10.8 Trapezoidal channel .....	30
5.3.10.9 Circular channel .....	30
5.3.10.10 Parabolic channel .....	31
<b>VI. Main functions .....</b>	<b>33</b>
<b>VII. Measuring weir and flume .....</b>	<b>33</b>
<b>VIII. Errors and Handling .....</b>	<b>40</b>
<b>IX. Structural dimension of the Parshall flume .....</b>	<b>42</b>
<b>X. Water level - flow formula of Parshall flume .....</b>	<b>43</b>
<b>XI. Ultrasonic Open Channel Flowmeter MODBUS Communication Protocol Version V1.4 .....</b>	<b>44</b>

## Brief Instructions

### 1. Display Interface

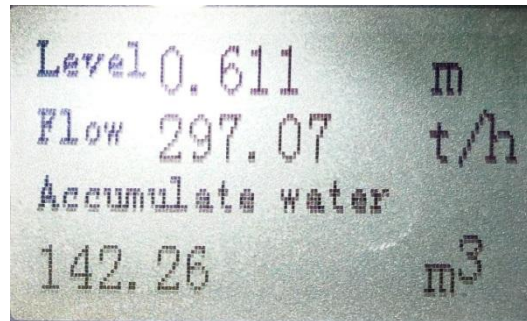

### 2. Buttons

There are three buttons on the panel, through which the meter can be commissioned. After commissioning, the measured value is displayed on the LCD screen.

#### SET Key

Functions: 1. Enter the menu items. 2. Exit the current menu item.  
3. Confirm parameter modifications.

#### ▲ ▼ Key

Functions: 1. Move the cursor. 2. Modify parameters.

### 3. Press (SET) to enter the first level menu.

Enter the height value of the probe into "reference zero", and the position of "reference zero" in the menu is shown in "2 Range setting" → "1 Reference Zero".

(The reference zero of triangular weir and rectangular weir is the distance between the launching surface of the probe and the water outlet of the weir and flume, not the distance to the bottom of the weir and flume.

The reference zero of Parshall flume is the distance from the launching surface of the probe to the bottom of the flume.)

### 4. Calibration of "4mA flow value" and "20mA flow value"

For 4mA flow value: 4mA is output when instantaneous flow is equal to this value.

For 20mA flow value: 20mA is output when instantaneous flow is equal to this value.

See the setting of "4mA flow value" and "20mA flow value" on the menu in "Setting" → "3. Menu operation instructions" → "10. Other parameters".

### 5. Type Selection of Measuring Weirs and Flumes

In terms of the selection, the size of the flow in the channel, the water regime in the channel, and the condition to form the free flow shall be

considered.

Generally speaking, there shall be enough fall to allow it to flow freely without being trapped in the downstream after the water passes through the weir or flume, and the downstream water will not be full.

Right triangle weir is recommended if the maximum flow is less than 40L/s (144t/h). If it is greater than 40L/s, Parshall flume is recommended. As the upstream channel is short and the maximum flow is greater than 40L/s, rectangular weir is recommended. The reference zero shall be calibrated first when the meter is used for measurement. The reference zero is the distance between the probe and the zero water level of the weir or flume. (The meter defaults to Parshall flume.)

### 5.1 Triangular Weir

If to adopt triangular weir, the operator can select "open" in "9 Type of weirs and flumes" on the menu → "1 Triangular weir" → "1 Working status". Then, the real angle can be selected in "2 Angle of triangular weir", and the corresponding flow rate can be calculated according to the water level.

### 5.2 Rectangular Weir

If to adopt rectangular weir, the operator can select "open" in "9 Type of weirs and flumes" on the menu → "2 Rectangular weir" → "1 Working status", and then select a value of "0.25m, 0.50m, 0.75m, 1.00m, non-standard channel" in "2 Standard channel", and the meter can calculate the flow rate according to the water level automatically.

### 5.3 Trapezoidal Weir

If to adopt trapezoidal weir, the operator can select "open" in "9 Type of weirs and flumes" on the menu → "2 Rectangular weir" → "1 Working status", and then input the actual weir sill width of the channel in "2 Weir sill width B", and the meter can calculate the flow rate according to the water level automatically.

### 5.4 Parshall Flume

If to adopt Parshall flume, the operator can select "open" in "9 Type of weirs and flumes" on the menu → "4 Parshall flume" → "1 Working status". The flow rate formula of Parshall flume is  $Q=Cb^{1.48}n$ . According to the throat wide "b", the repair work coefficient c and exponent n can be found out from "Schedule II Parshall Flume Water Level - Flow Formula". Then the operator can select the menu "9 Type of weirs and flumes" → "4 Parshall flume", and input "2 Repair work coefficient c and "3 Index n". The meter can calculate the flow rate according to the water level automatically.

## I. Purpose

The water flow in the open channel can be measured through the match use

of ultrasonic open channel flowmeter and the measuring weirs and flumes. It is mainly used for the flow of the measuring sewage discharge outlets of sewage plants, enterprises and institutions, the flow of urban sewage and irrigation channels.

## **II. Principles**

This series of meters are to directly measure the liquid height in a channel or flume. When it is used to measure the flow of open channel, the measuring weir and flume shall be installed on the open channel. The measuring weir or flume changes the flow rate in the open channel to the level of liquid. The meter measures the water level in weirs or flumes first and calculates the flow rate according to the relationship between water level of the measuring weir and flume and the flow rate.

### **1、 Principle of Ultrasonic Liquid-level Measurement**

The ultrasonic pulse emitted by the transmitting ultrasonic transducer is transmitted to the measured surface through air. After that, it is returned to the receiving transducer by air after reflection. Then, the time of ultrasonic pulse transmitted and received in sound transmission media is measured. Based on the speed of sound in the air, the distance from the transducer to the liquid level can be calculated. The liquid level is therefore determined. So, we can calculate the distance from the probe to the reflective surface  $D = C * t/2$  (divided by 2 because the sound wave is a round-way from transmitting to receiving. D indicates the distance, C indicates the speed of sound, t indicates the time). Then, the liquid level can be calculated by subtraction.

### **2、 Principle of Water Flow Measurement in Measuring Weirs and Flumes**

The larger the flow in the open channel with smooth circulation, the higher the liquid level. The smaller the flow, the lower the liquid level (as shown in Fig. 2.1). The flow can be calculated by measuring the water level. The corresponding relationship between flow and water level in ordinary open channels is affected by slope ratio and surface roughness. The measuring weirs and flumes in the channel can be installed for throttling, so that the flow rate and liquid level in the open channel have a fixed corresponding relationship, which mainly depends on the size of measuring weirs and flumes, and minimize the influence of the channel as far as possible.

Right triangle weir, rectangular weir and Parshall flume are commonly used.

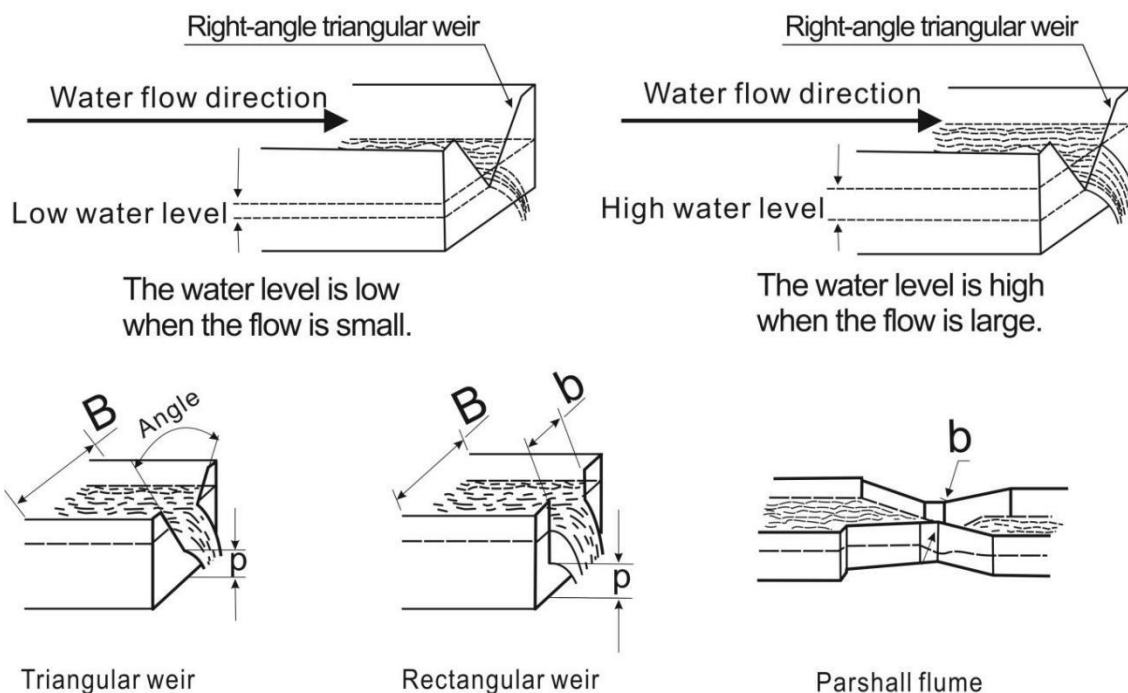

If to use the ultrasonic open channel flowmeter, it is necessary to know the relationship between the water level of the measuring weir or flume and the flow before the installation.

The relationship between the water level of the measuring weir or flume and the flow can be found out in the national metrology verification regulation, *Verification Regulation of Weirs and Flumes for Flow Measurement (JJG711-90)*, a part of which is excerpted for this manual. After the throat width of the Parshall flume is known as  $b$ , the corresponding relationship between water level-flow can be calculated by the corresponding formula.

The relationship for that of the right triangle weir can also be calculated with this formula.

Rectangular weir also has a corresponding formula, and it's also related to the size of the channel being installed. During the determination of water-flow relationship, the width  $B$ , opening width  $B$  and upstream weir ridge height  $p$  shall be considered.

If you are not familiar with the calculation of the water level of the weir/flume and the flow, you can inform the meter manufacturer of the parameters of the measuring weirs and flumes. The manufacturer shall help the calculation. It shall be noted that the above parameters related to the determination of the water-flow relationship shall also be provided.

### III. Main Technical Indicators

Functions	Integral-type	Split type
Probe selection	<p><b>Sensor selection:</b>                      It is suggested to adopt 100KHz M48×2 probe for No. 1-4 Parshall flume. The measuring range is 1m, so that it is not likely to hit the wall of the Parshall flume or corners to form a false signal.</p>	

	<p>The M48×2 probe has a small blind area, only 10 cm, and the mounting bracket can be made even lower.</p> <p>It is suggested to adopt 64Khz M48×2 probe for No. 5-25 Parshall flume. The measuring range is 2m, and the blind area is 30cm.</p>	
<b>Measuring range</b>	Parameters ranging from 0.1L/s ~ 99999.99m <sup>3</sup> /h can be determined according to different weirs and flumes.	
<b>Accumulative flow</b>	Max.: 4290000000.00m <sup>3</sup>	
<b>Maximum range of liquid level</b>	It can be made for three types, 1m, 2m and 3m. If large range is required, it shall be customized.	
<b>Liquid level measurement accuracy</b>	0.5%	
<b>Resolution</b>	3mm or 0.1% (whichever is greater)	
<b>Display</b>	Chinese LCD display	
<b>Flow measurement accuracy</b>	1~5% is for standard weirs and flumes (those meet the requirements of the national standards.) 10~50% if for non-standard weirs and flumes.	
<b>Analog output</b>	4-wire 4~20 mA/600Ω load	
<b>Relay output</b>	(Option) 2 groups of AC 220V/ 8A or DC 24V/ 5A,	
<b>Power supply</b>	220V AC±15% 50Hz, or 24VDC 120mA;	
<b>Power supply</b>	(Option) 12VDC, battery power supply, solar power supply	
<b>Working environmental temperature</b>	Display meter -20~+60°C, probe -20~+80°C	
<b>Working environmental pressure</b>	Normal atmosphere	
<b>Working environmental humidity</b>	≤90%RH, non-condensation	
<b>Process temperature</b>	-20~+80°C;	
<b>Process pressure</b>	Normal atmosphere	
<b>Telecommunication</b>	Optional 485 and 232 communication, MODBUS protocol	
<b>Protection class</b>	Display meter IP65, probe IP68	Display meter IP64, probe IP68

<b>Probe cable</b>	None	Standard 10m, 100m at maximum
<b>Probe material</b>	The standard material is ABS, and anti-corrosive material shall be used in corrosive environment.	

<b>Split-type product power consumption</b>	<p>The split-type meter is powered by 24V power supply, and the power consumption without relay is 100mA. It needs 120mA if with one relay, 145mA if with two relays, 170mA if with three relays and 190mA if with four relays.</p> <p>Specific power is as follows:  <math>24 \times 100\text{mA} = 2.4\text{W}</math> for no relay;  <math>24 \times 120\text{mA} = 2.9\text{W}</math> for 1-way relay; <math>24 \times 145\text{mA} = 3.5\text{W}</math> for 2-way relay;  <math>24 \times 170\text{mA} = 4.1\text{W}</math> for 3-way relay; and <math>24 \times 190\text{mA} = 4.6\text{W}</math> for 2-way relay;</p>
<b>Integral-type product power consumption</b>	<p>The integral four-wire system is powered by 24V power supply, and the power consumption without relay is 80mA. It needs 105mA if with one relay, and it needs 130mA if with two relay.  <math>24 \times 145\text{mA} = 3.1\text{W}</math> is for 2-way relay</p>

## IV. Installation

### 4.1 Shape of Open Channel Flowmeter

#### 4.1.1 Drawings of Profile and Dimension of Split-type Open Channel Flowmeter Display Meter



Drawing of Open Channel Flowmeter

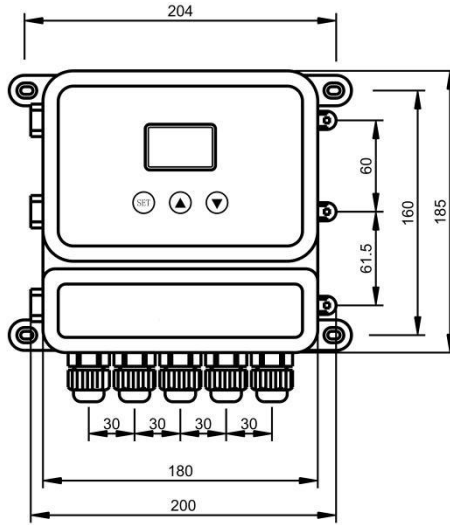

Structure Drawing of Open Channel Flowmeter

The meter display of the split-type ultrasonic open channel flowmeter should be installed indoors. The room should be well ventilated and free from corrosive gases. The meter shall be mounted on the wall. If the indoor conditions are not good or it shall be hung in the outdoor, it shall be installed in the meter protection box to avoid the sun exposure and rain.

#### 4.1.2 Drawings of Profile and Dimension of Integral Open Channel Flowmeter

##### 4.1.2.1 Probe M48 x 2

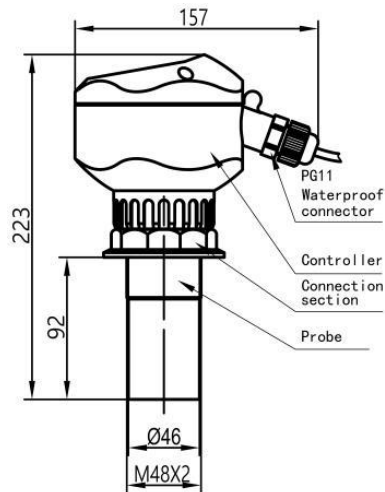

##### 4.1.2.2 Probe G2

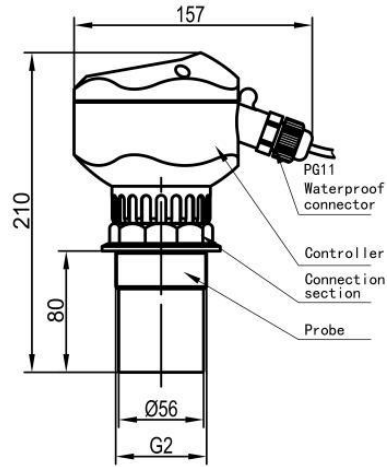

#### 4.1.2.3 Probe M78 x 2

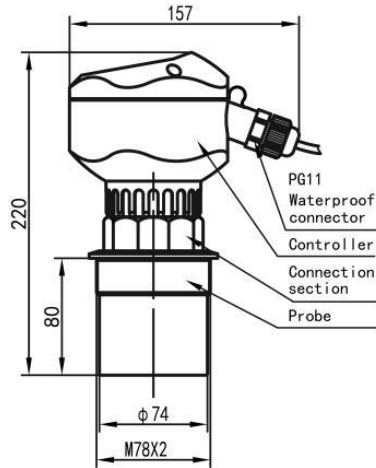

### 4.2 Probe Installation

The probe of ultrasonic open channel flowmeter can be installed directly above the observation point of water level of the measuring weir and flume. The probe transmitting surface shall align and perpendicular to the water surface. A level can be placed on the top cover of the probe and the probe shall be leveled to align the water surface. The water level observation point of Parshall flume shall be 0.1 ~ 0.5 m from the upstream of the flume; and that of triangular weir and rectangular weir shall be on one side of the upstream, which is 3 ~ 4 times of the maximum water depth through the weir away from the weir plate.

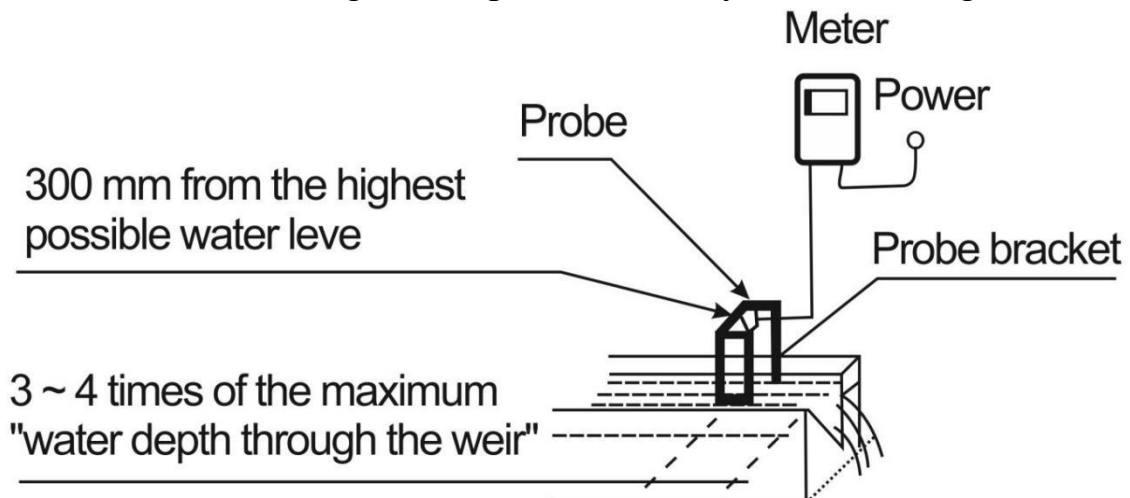

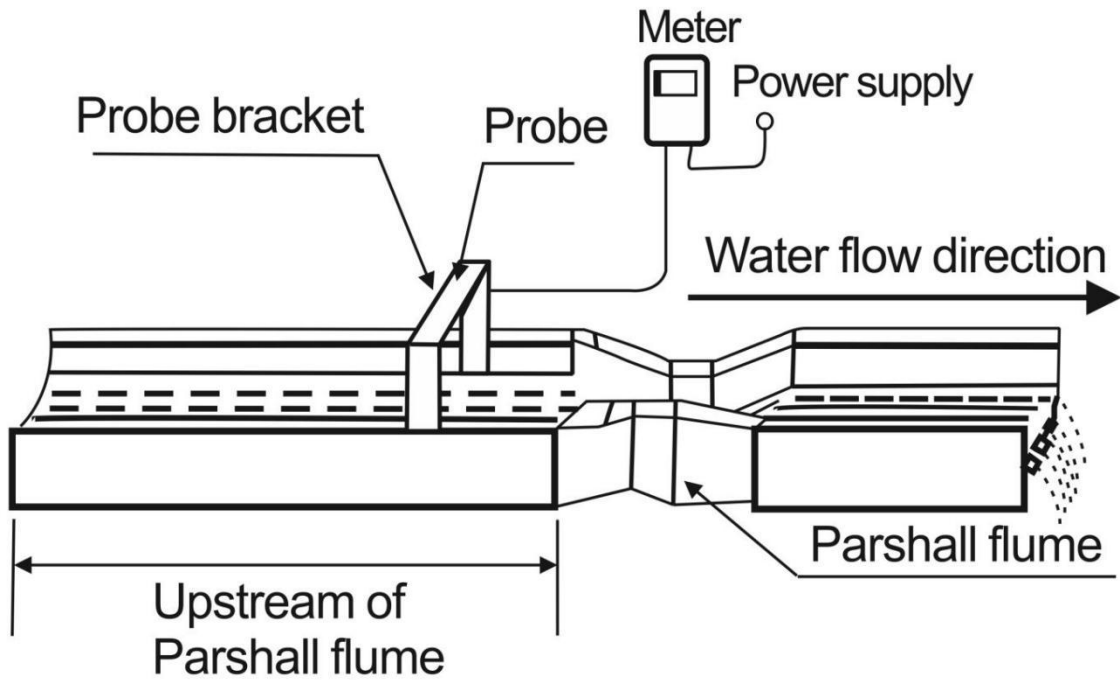

#### 4.2.1 Bottom thread mounting

1. Install a flange above the measured object.



2. Put a gasket of the same inner diameter on the flange.



3. Align the transducer with the flange hole.



**4.Put the transducer into the flange hole.**



**5.Observe through the flange bottom.**



**6.Put a gasket of the same inner diameter under the flange.**



**7.Screw on the nut and fix the transducer.**



**8.Install the transducer.**



**4.2.2 Top thread mounting - Hoisting installation**

**1.Screw threads on top of probe with nuts.**

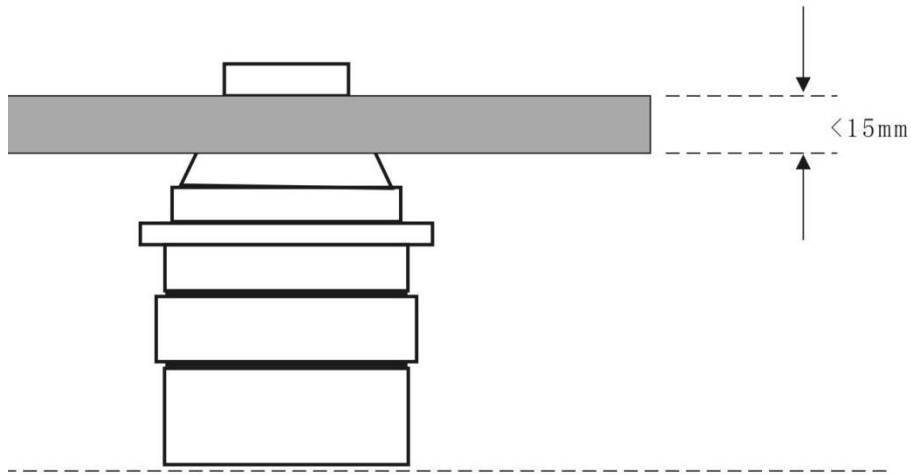

## 2. Use protective tube for probe incoming line.

▲ The installation on the tank, sink, cover plate and bracket are the same as above.

★ After the probe is installed, the cover plate or wave guide tube shall be exposed on the transmitter surface of the probe. They shall not be hid inside the cover or guide tube.

### 4.2.3 Stilling Well Installation

In many cases, there are measurement errors or no measurement signal because the water in the channel may have garbage, foam or other floating objects; or because there are no straight channels of sufficient length upstream and the water surface fluctuates greatly. In that case, stilling well can be used.

The inner wall of the stilling well shall be  $> 50\text{cm}$  in diameter, and the inner wall shall be smooth without any bumps and burrs. After the probe is installed, the transmitting surface of the probe shall be  $> 0.3\text{m}$  away from the highest water surface.

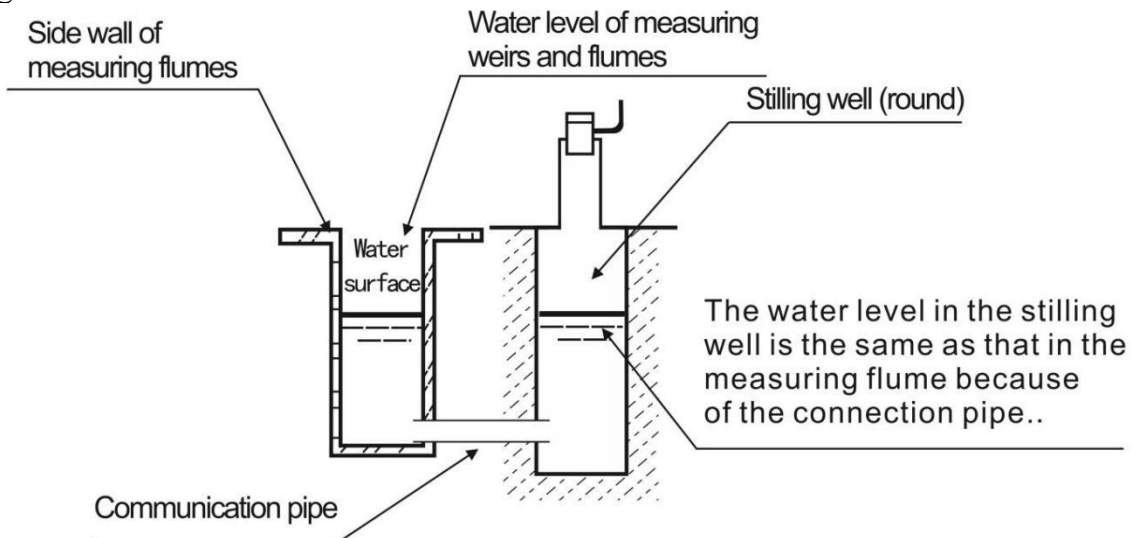

## 4.3 Site Installation Drawing of Weirs and Flumes for Open Channels

### 4.3.1 Installation of triangular weir



### 4.3.2 Installation of rectangular weir





### 4.3.3 Installation of Parshall flume



### 4.4 Installation of Weirs and Flumes

4.4.1 The center line of the measuring weir and flume shall be aligned with the center line of the channel to make the water flowing into the weir and flume without bias current.

4.4.2 After water flows through the measuring weir and flume, the water shall

have free flow.

The downstream water level of triangular weir and rectangular weir is lower than the weir ridge. The submergence degree of the Parshall flume is less than the critical submergence degree in the "Parshall flume parameters".

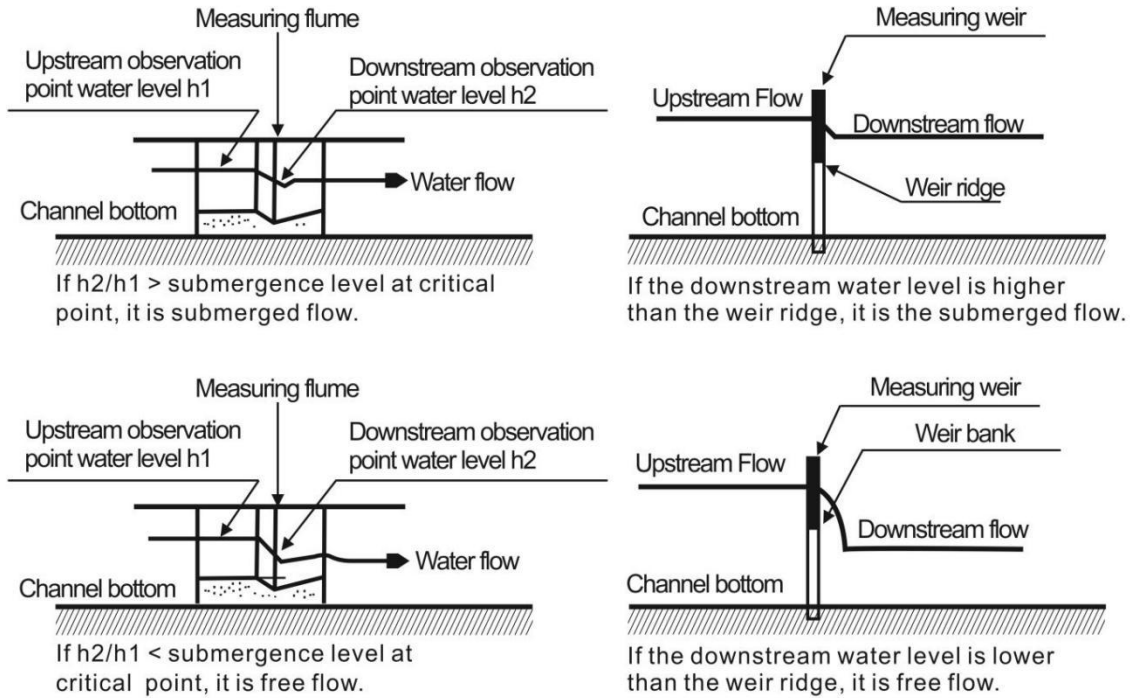

4.4.3 There shall be flat and straight section greater than 10 times the width of the channel in the upstream of the measuring weir and flume at minimum, so that the water flow can enter the measuring weir and flume smoothly, for which there shall be "no spray on the water surface". That is, there shall be no left and right drift, nor the channel slope formed by the thrust.

If the upstream of the measuring weir and flume is less than 10 times of the flat and straight section, and the water flow fluctuates greatly or there is a large amount of foam, two layers of dampers with holes can be added, as shown in the figure below.



4.4.4 The measuring weir and flume shall be fixed on the channel. It should be closely connected with the side wall and the bottom of the channel without water leakage. The water flow shall flow through the measuring part of the weir and flume. The measuring part of water measuring weir plate is the weir crest, and the that of the measuring flume is the throat section in the flume.

## 4.5 Wiring Diagram

### 4.5.1 Drawing and Schematic Diagram of Connection Terminals of Split-type Open Channel Flowmeter

#### 4.5.1.2 220VAC power supply

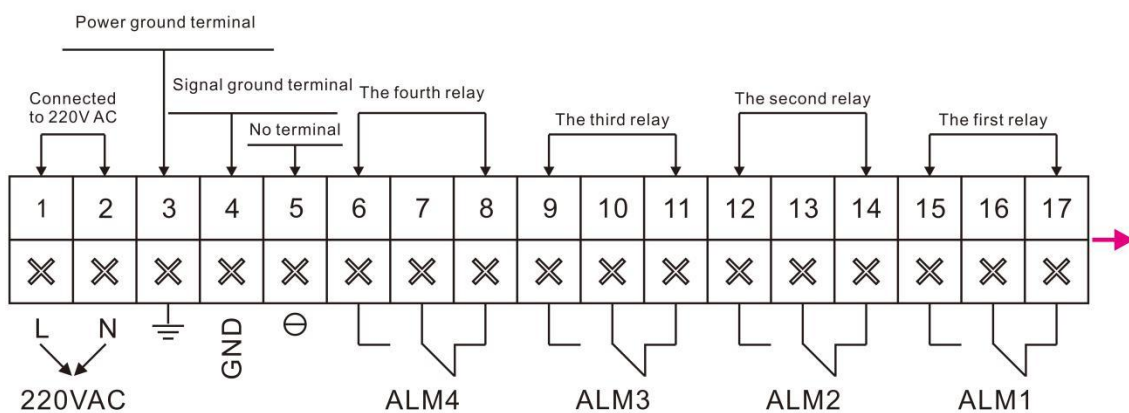

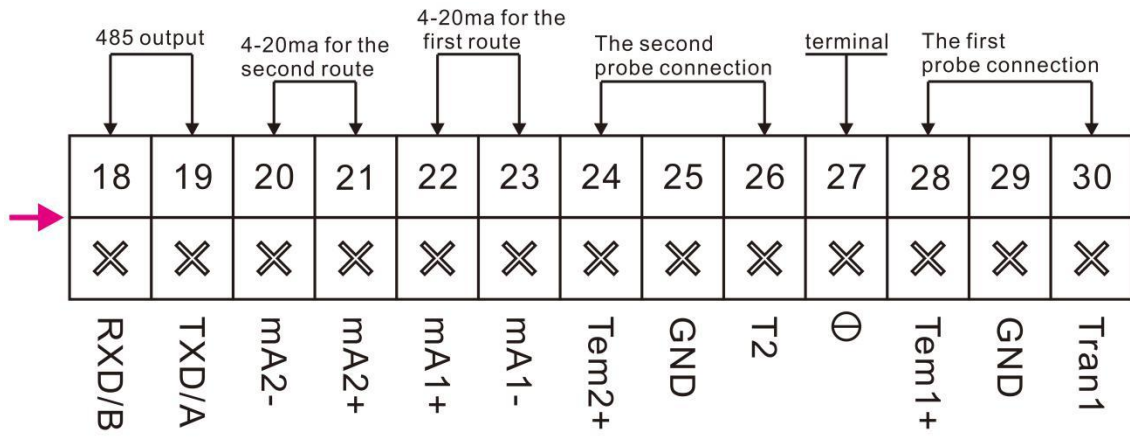

### 4.5.1.3 24VDC power supply

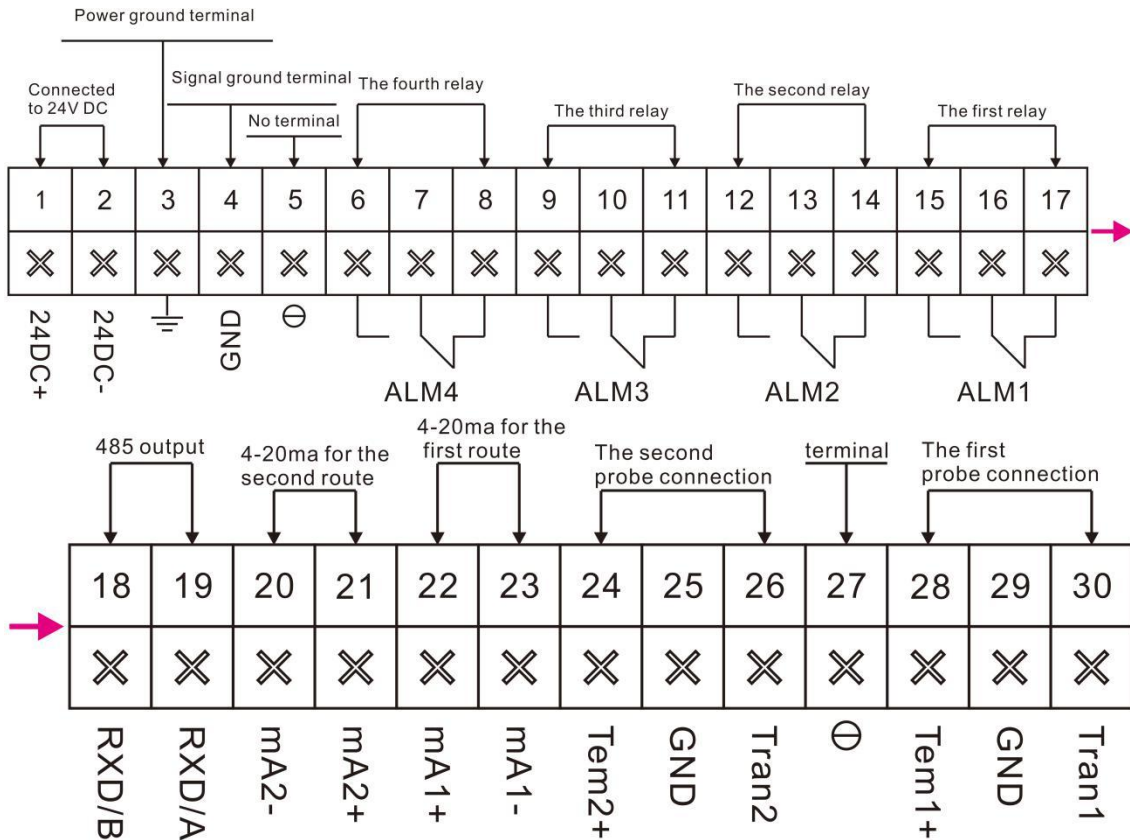
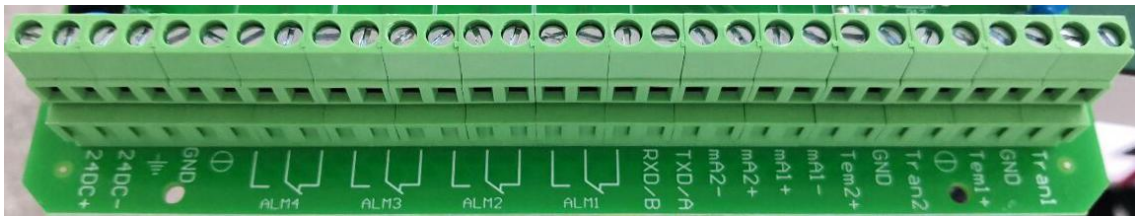

### 4.5.1.3 Wiring method:

Transducer: red line: Trans1 transducer, blue line: connected to Temp 1 + temperature sensor + Black line + shield line: GND ground wire

Current output: anode current is connected to "mA1" +; cathode current is connected to "mA- /GND".

Relay: RLnA and RLnB are normally open;

If the relay is to be "normally open" by default, RL1nA and RL1nB shall be connected. RL1nA and RL1nC are normally closed;

If the relay is to be normally closed by default, RL1nA and RL1nC shall be connected.

Power line: 220VAC AC: connected to L, N

DC: 24V+ is connected to 24VDC+, and GND is connected to 24VDC -.

Wiring of 485: 485A is connected to "TXD/485A" terminal, and 485B is connected to "RXD/485B" terminal.

Wiring of 232: TXD is connected to "TXD/485A" terminal, and RXD is connected to "RXD/485B" terminal.

The ground wire of 232 connected to "mA-/GND" terminal.

## 4.5.2 Schematic Diagram of Terminal of Integral Ultrasonic Open Channel Flowmeter

### 4.5.2.1 24VDC power supply



1	2	3	4	5	6	7	8	9	10
X	X	X	X	X	X	X	X	X	X
24VDC+	24VDC-	mA-	mA+	485B	485A	RL1+	RL1-	RL2+	RL2-
└───┬───┘		└───┬───┘		└───┬───┘		└───┬───┘		└───┬───┘	
24 power supply		4-20mA output		485 output		Relay 1		Relay 2	

### 4.5.2.2 220VAC power supply

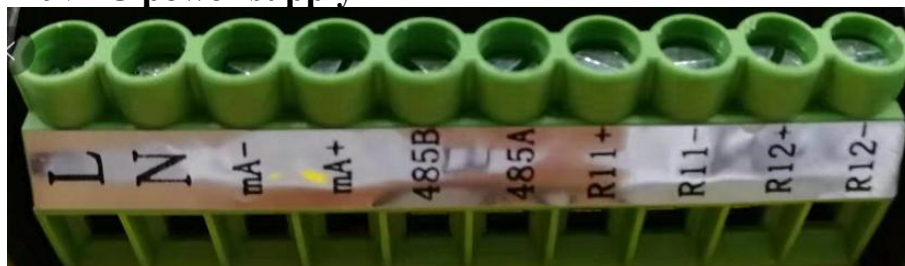

1	2	3	4	5	6	7	8	9	10
X	X	X	X	X	X	X	X	X	X
L	N	mA <sup>-</sup>	mA <sup>+</sup>	485B	485A	RL1 <sup>+</sup>	RL1 <sup>-</sup>	RL2 <sup>+</sup>	RL2 <sup>-</sup>
220VAC		4-20mA output		485 output		Relay 1		Relay 2	

#### 4.5.3.3 Wiring method:

Current: current + is connected to mA +, and current - is connected to mA -.

Relay: it is connected to RL<sub>n</sub>+ and RL<sub>n</sub>- terminals, which are normally open. n = 1 or 2, indicating the first relay or the second relay.

Power line: In case of 220V AC, the live wire is connected to L terminal and the neutral line is connected to N terminal.

DC: power supply 24V + is connected to 24V+ terminal, and the 24V- is connected to 24V- terminal.

Wiring of 485: 485A is connected to "485A" terminal, and 485B is connected to "485B" terminal.

Wiring of 232: TXD is connected to "485A" terminal, and RXD is connected to "485B" terminal. The ground wire of 232 connected to "mA-" terminal.

## V. Settings

### 5.1 Interface Introduction of Operation Mode

This series of ultrasonic open channel flowmeter has two working modes: operation mode and setting mode. After the equipment is energized and the initialization process is completed, the flowmeter will automatically enter the operating mode and start measuring and date recording.

### 5.2 Menu Instruction

There are three buttons on the meter: Up, Down and SET.

Set button: Select enter or confirm exit.

Up and Down buttons: Move the cursor up and down, select options in the selection box, and select or modify values in the input box.

View the echo status diagram: hold down "▲" first, then hold down the "SET" button for more than 3s, you can see the echo status diagram.

Exit echo status diagram: hold down "▼" and hold down "SET" for more than 3s to exit the echo status diagram.

### 5.3 Menu Interface and Operation Instructions

#### 5.3.1 Press Set button in operation mode interface to enter into the interface of Level 1 menu:

##### 5.3.1.1 Level 1 menu interface without locked parameters:

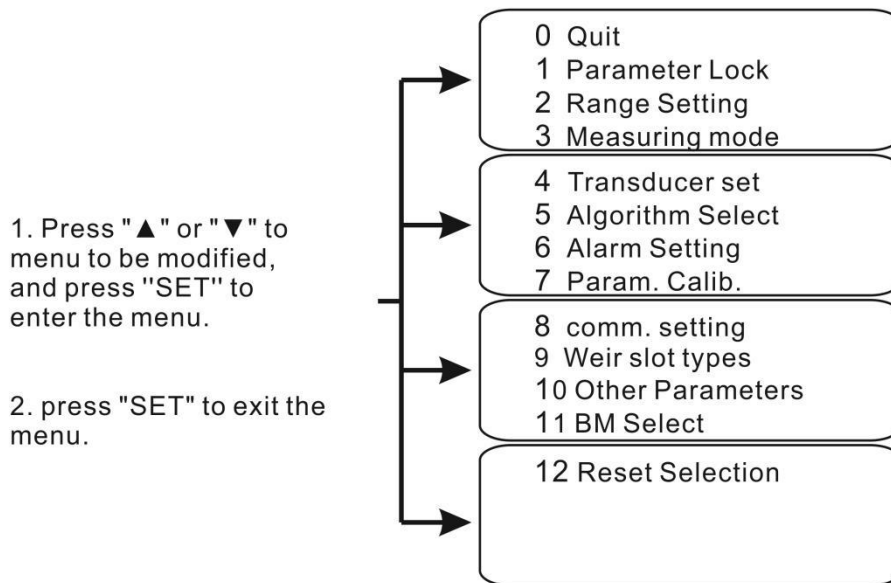

### 5.3.1.2 Level 1 menu interface with locked parameters:

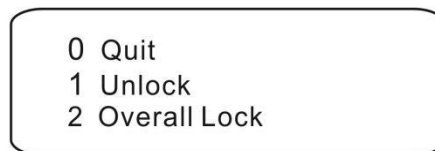

## 5.3.2 Description of Level I Menu

### 5.3.2.1 "0 End setting"

Choose this item and press Set button to return to operation mode interface.

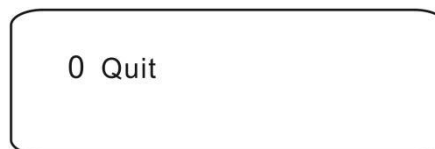

### 5.3.2.2 "1 No locking"

The menu is not locked, able to be modified.

### 5.3.2.3 "2 Overall locking"

The menu is locked. If you have finished setting and do not allow any modification, press this button to lock the menu. Person who wants to modify the settings have to enter the password to unlock the menu. The initial password of the current meter is 25, user can change it (Please remember the password, or have to contact the manufacturer to retrieve the password).

**★If parameters are not locked, press Set button to enter into the parameter locking interface:**

**No locking:** all menus can be mended.

**Overall locking:** menu can be modified after password is input.

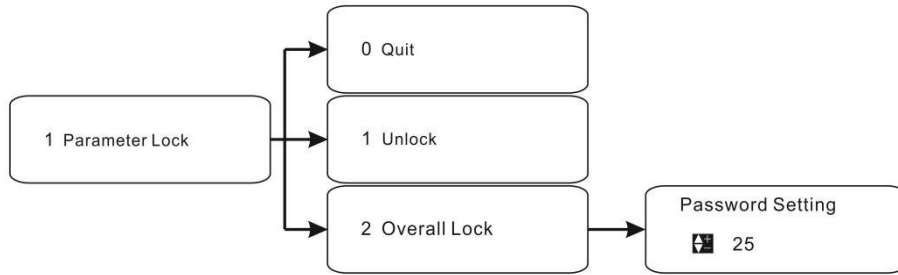

★If parameters are locked, press Set button to enter into the unlocking interface:



### 5.3.3 "2 Range setting"

**1 Reference zero:** Set the reference zero point of the open channel flowmeter. It is of meaning when the object level is measured. The factory setting defaults to the value corresponding to the maximum range.

**2 Low range point:** Set the measured value corresponding to the output of the object level meter 4mA; and it can be used as the low flow limit setting value, that is, when the liquid level is less than the set value, the flow rate is 0. The factory setting defaults to 0.

**3 High range point:** Set the measured value corresponding to the output of the object level meter 4mA; and it can be used as the low flow limit setting value, that is, when the liquid level is less than the set value, the flow rate is 0. For example, if it is set to 0.5m, it means that when the liquid level exceeds 0.5m, the flow is maintained at 0.5m. The factory setting defaults to maximum range.

**4 Display unit:** there are three units, m, cm and mm. m indicates meters, cm indicates centimeters and mm indicates millimeters. The factory setting defaults to m.

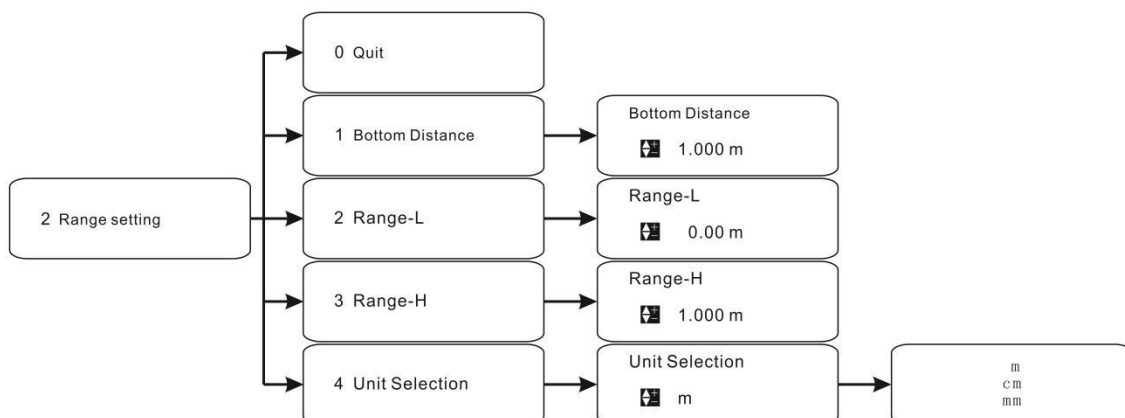

### 5.3.4 "3 Measurement mode"

**1 Mode selection:** There are two options, distance measurement and level measurement. Distance measurement: The display value is the distance between the probe and the measured plane. Level measurement: The display value is the distance from the reference zero point to the liquid level. The factory setting defaults to level measurement.

**2 Response speed:** There are three options: slow, medium and fast. Slow: slow response rate, high measurement accuracy, not easy to be disturbed. Medium: it is between slow speed and fast speed. Fast: fast response rate, low measurement accuracy, easy to be disturbed. The factory setting defaults to medium speed.

**3 Safe level:** There are four options: hold, minimum, maximum and setting. Hold: the display value after the system wave loss is the last measured value, and the current is the corresponding value. Minimum value: the display value after the system wave loss is 4mA, and the current is 4mA. Maximum value: the display value after the system wave loss is 20mA, and the current is 20mA. Setting value: the display value after the system wave loss is the final measured value, and the current output is the setting value of the set current. The factory setting defaults to "hold".

**4 Current setting:** It is to set the output of the specified current after wave loss, greater than 3.6mA and less than 22mA. When hold/maximum/minimum value is selected, it is invalid. The factory setting defaults to 3.6mA.

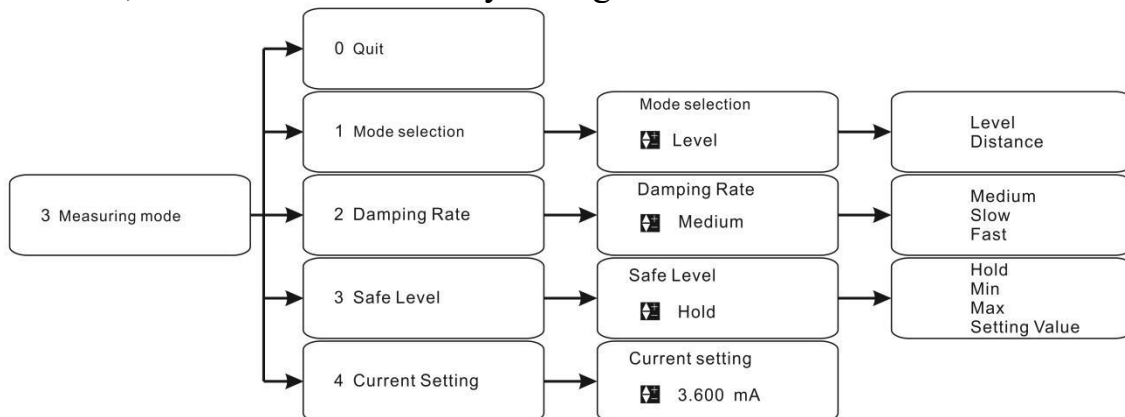

### 5.3.5 "4 Probe setting"

**(Please do not modify it, it is for factory set)**

**1 Probe type:** Please do not modify by yourself. It can only be modified under the guidance of professional technicians.

**2 Blind area setting:** Please do not modify by yourself. It can only be modified under the guidance of professional technicians.

**3 Short sensitivity:** Please do not modify by yourself. It can only be modified under the guidance of professional technicians.

**4 Short threshold:** Please do not modify by yourself. It can only be

modified under the guidance of professional technicians.

**5 Long sensitivity: Please do not modify by yourself. It can only be modified under the guidance of professional technicians.**

**6 Long threshold: Please do not modify by yourself. It can only be modified under the guidance of professional technicians.**

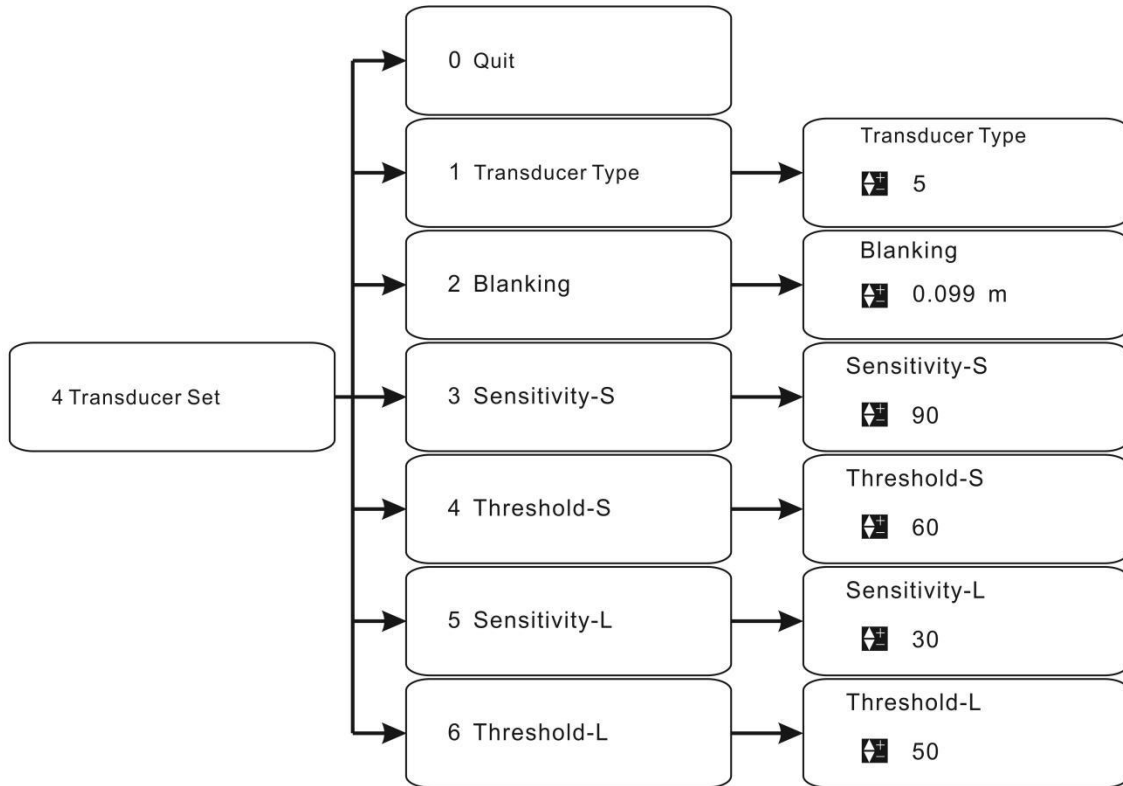

### 5.3.6 "5 Algorithm selection"

**(Please do not modify it, it is for factory set)**

**Algorithm selection:** There are seven options: special environment 1, special environment 2, special environment 3, special environment 4, special environment 5, special environment 6 and special environment 7. The factory setting defaults to special environment 7.

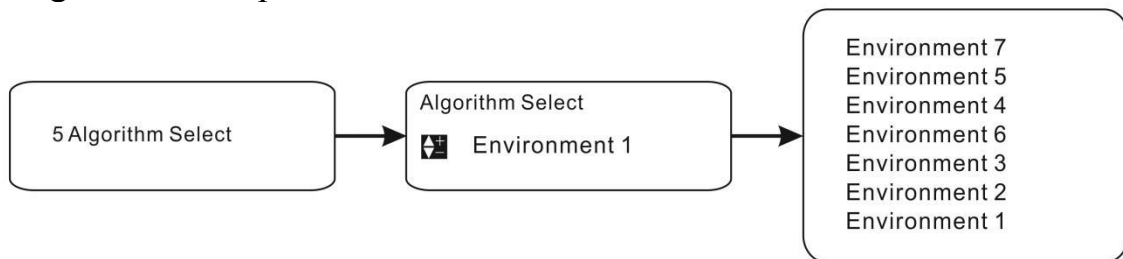

### 5.3.7 "6 Alarm setting"

#### 1 Instantaneous flow rate alarm mode:

It is used for the upper and lower limit alarm for instantaneous flow. There are three options, off alarm, low alarm and high alarm. Off: relay 3 does not work; Low alarm: for relay 3; High alarm: for relay 3. The factory setting defaults to "off".

#### 2 Instantaneous flow rate alarm value:

The unit is m<sup>3</sup>/h, and the factory setting defaults to 0.

### 3 Return difference of instantaneous flow rate alarm value:

The unit is m<sup>3</sup>/h. After the alarm is triggered, the alarm can be removed only when the measured value reaches the alarm value +/- the alarm return difference. The factory setting defaults to 0.

### 4 Cumulative flow rate proportional output:

There are two options: Off and on. Off: relay 4 does not work; On: for relay. The factory setting defaults to "off".

### 5 Preset cumulative flow rate:

The unit is m<sup>3</sup>, and the factory setting defaults to 0.

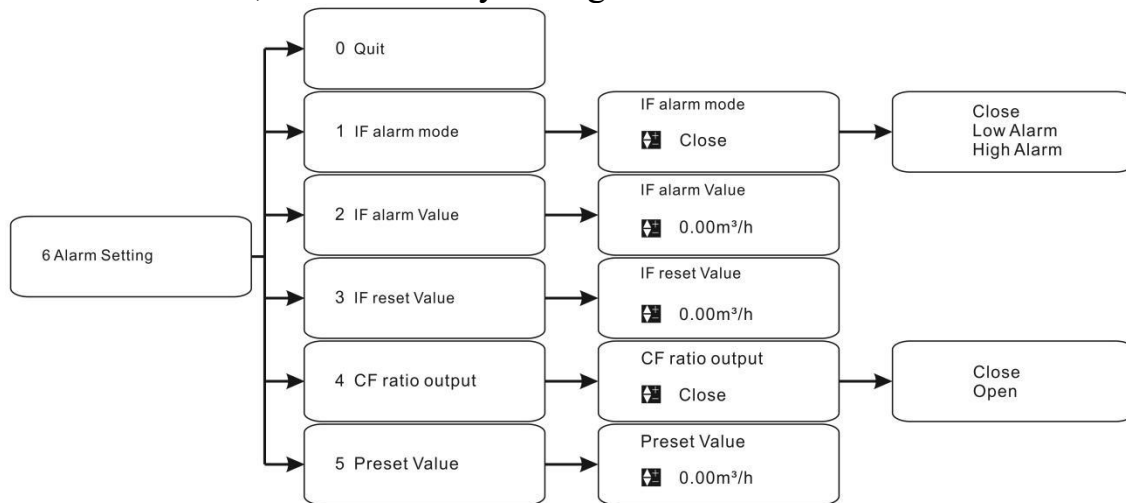

### 5.3.8 "7 Parameter calibration"

**(Please do not modify it, it is for factory set)**

The range calibration, sound velocity calibration, current output calibration and reference level calibration shall be performed.

**Range calibration:** Input the actual value, and the system automatically calibrates the range.

**The parameter is not allowed to be commissioned.**

**Sound velocity calibration:** Input the actual value and the system automatically calibrates the sound velocity, which is used when the air is not involved in the gas.

**The parameter is not allowed to be commissioned.**

**4mA calibration:** Modify the value until the actual output current is 4mA.

(Press ▲ to increase a numerical value each time the item is used. For example, increase the value from 1000 to 10001, and then the value 4ma will be output.)

**20mA calibration:** Modify the value until the actual output current is 20mA.

(Press ▲ to increase a numerical value each time the item is used. For example, increase the value from 5000 to 50001, and then the value 20ma will be output.)

**Reference level:** Enter the voltage measured at the corresponding test point. The factory setting defaults to 5.00.

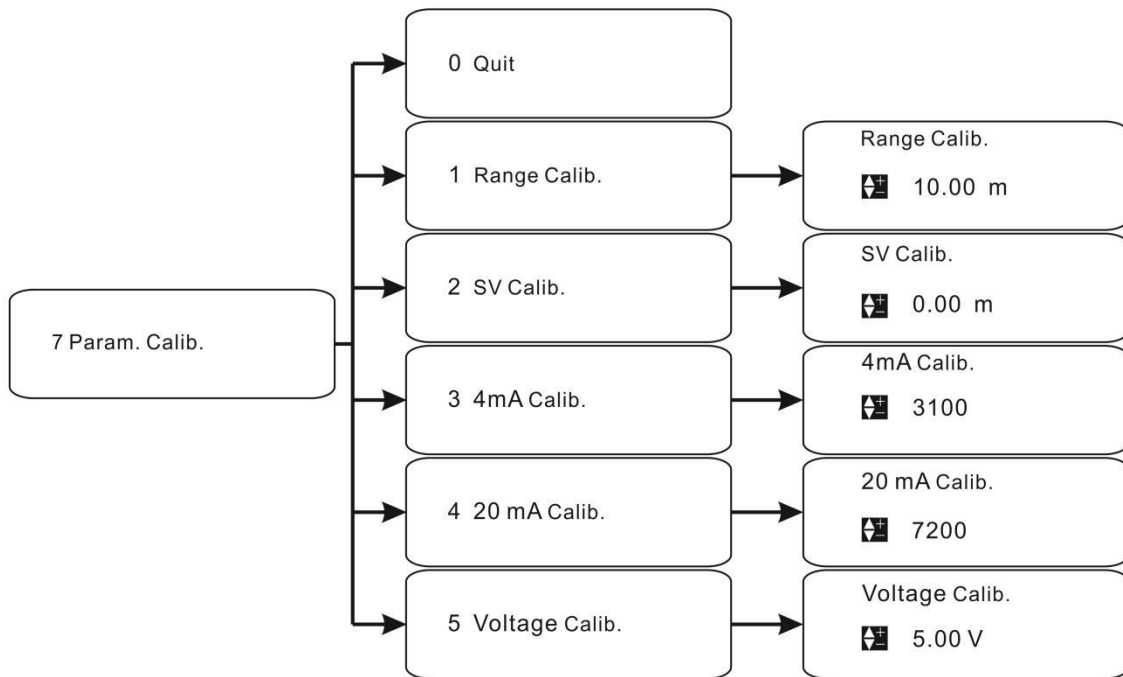

### 5.3.9 "8 Communications setting"

**1 Communication address:** Select the communication address, and the default value is 1.

**2 Baud rate:** Select the communication frequency among 2400, 4800, 9600 and 19200, and the default value is 9600.

**3 Working mode:** There are automatic report mode and query mode. "Automatic reporting" is to send the data to the upper computer by ultrasonic open channel flowmeter automatically, with no need of the query command from the upper computer. (Automatic report mode is only available for manufacturer protocol. MODBUS protocol has no automatic report mode.) "Query mode" is that only when the upper computer gives a query command answer the open channel flowmeter once.

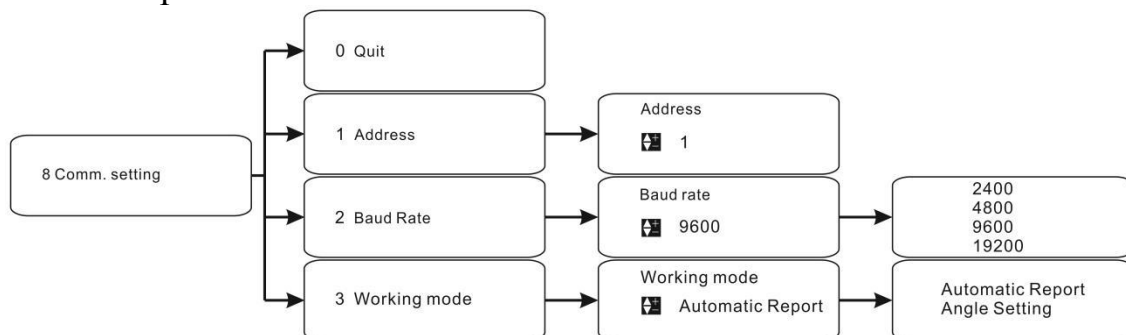

### 5.3.10 "9 Type of weirs and flumes"

#### 5.3.10.1 Triangular weir:

**Working status:** off, indicating that triangle weir is not selected; and the default value is "off."

On: it indicates that the triangle weir is selected.

**Angle of triangular weir:** the angle of 90° (30°/60°/45°) corresponds to the angle of the triangle weir. The user only needs to select different angles, and the machine can automatically calculate the flow value according to the water level value.

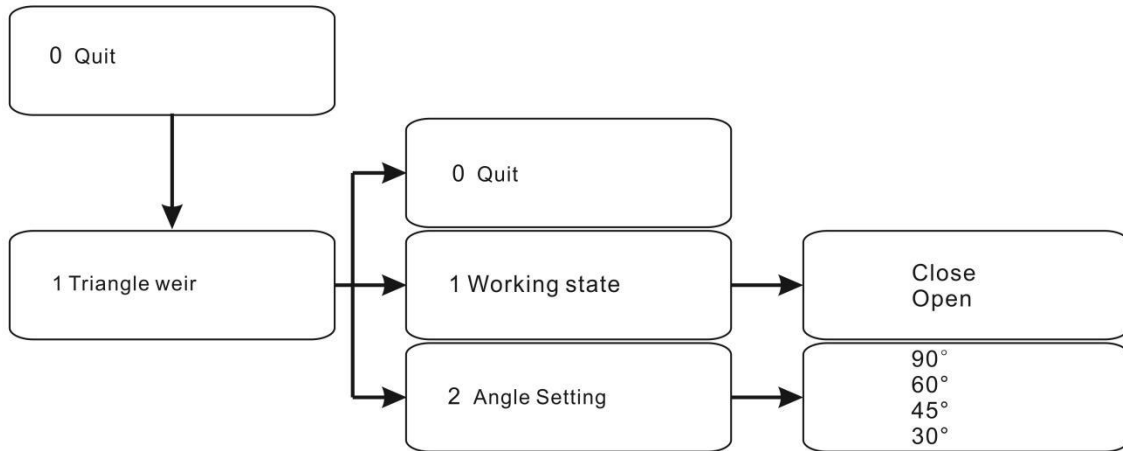

### 5.3.10.2 Rectangular weir:

**Working status:** off, indicating that rectangular weir is not selected; and the default value is "off." On: it indicates that the rectangular weir is selected.

**Standard channel:** 0.25m (0.50m / 0.75m / 1.00m/non-standard channel): these values represent the throat width of rectangular weir. For a rectangular weir whose throat width is 0.25m, users only need to select different throat widths, and the machine will automatically calculate the flow value according to the water level value.

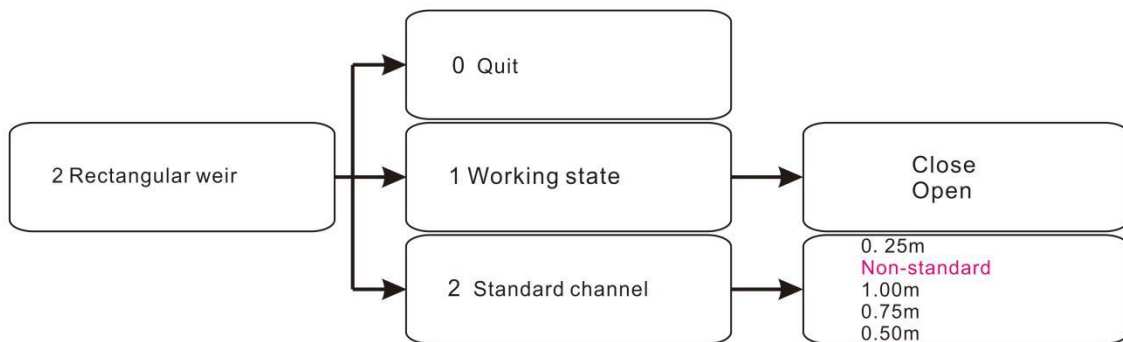

**In the rectangular weir, after the "non-standard channel" is selected, the menu of rectangular weir will be three more items: 3 weir mouth width b; 4 upstream channel width B; 5 weir wall height P. The user can input according to the actual channel size.**

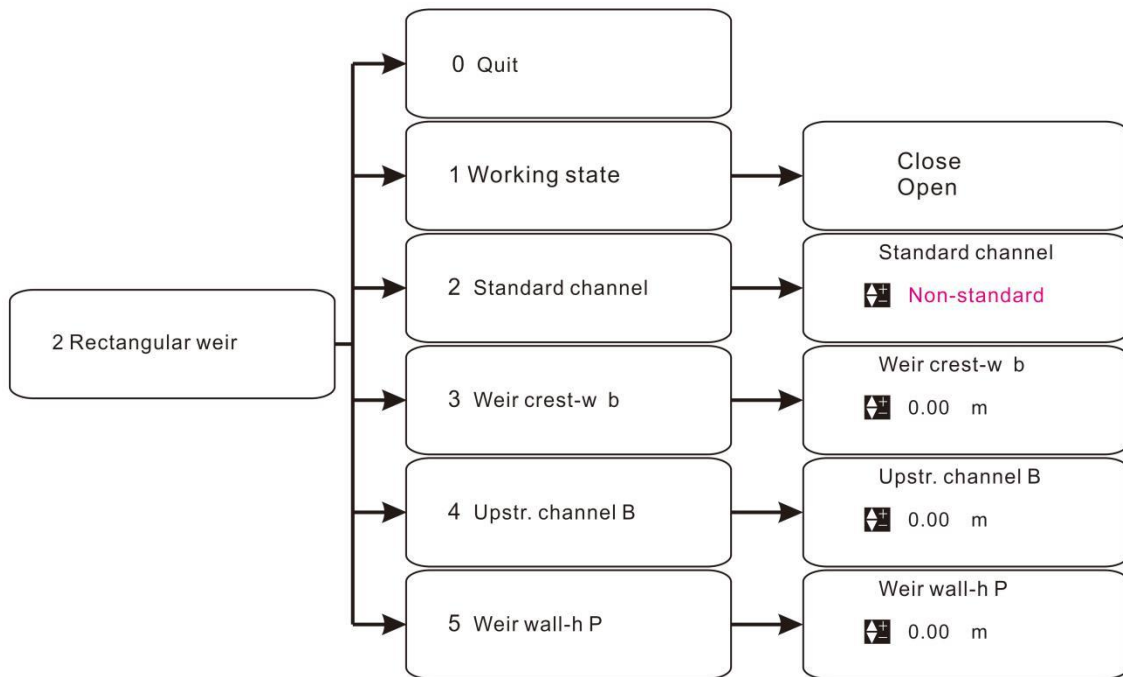

### 5.3.10.3 Trapezoidal weir:

**Working status:** off, indicating that trapezoidal weir is not selected; and the default value is "off".

On: it indicates that the trapezoidal weir is selected.

**Weir sill width B:** The user can input according to the actual channel size, and the machine will calculate the flow value automatically according to the water level value.

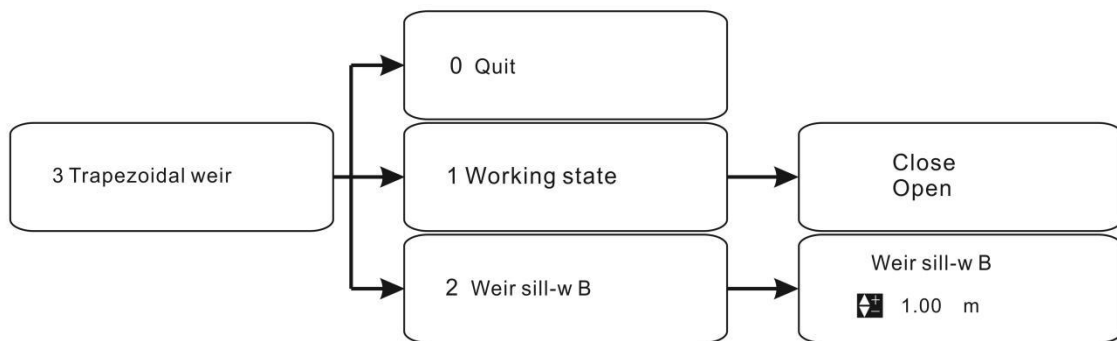

### 5.3.10.4 Parshall flume:

**Working status:** off, indicating that Parshall flume is not selected; on, indicating that it is selected, and when the default value is "on", the Parshall flume is selected by default.

**Repair work coefficient c:** Set value C according to the supporting weir and flume. The factory setting defaults to 0.01.

**Index n:** Set value n according to the supporting weir and flume. The factory setting defaults to 0.01.

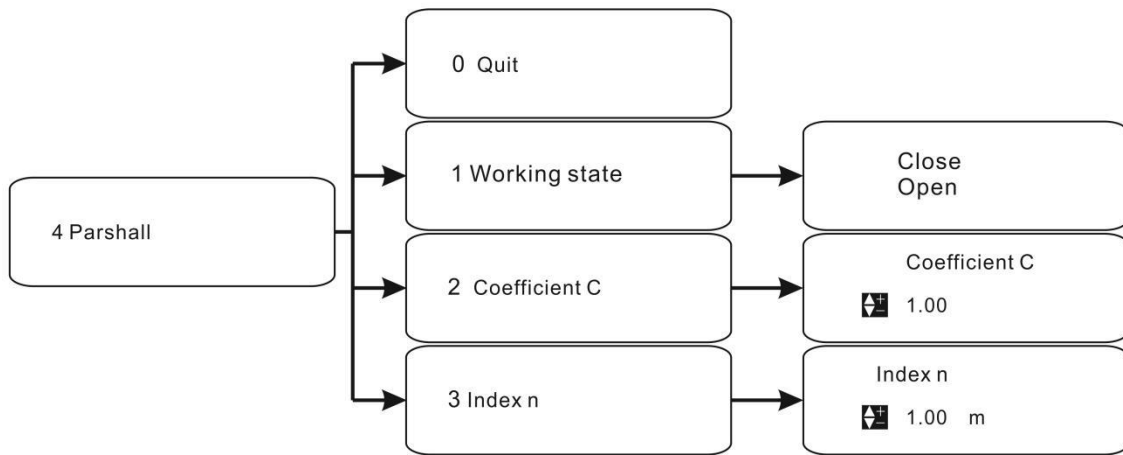

**Special attention:** At this time, the user is required to input repair coefficient  $c$  and index  $n$ , then the user can find out two parameters of repair coefficient  $c$  and index  $n$  according to the flume of different specifications, as shown in Table 2.

### 5.3.10.5 U-shaped channel

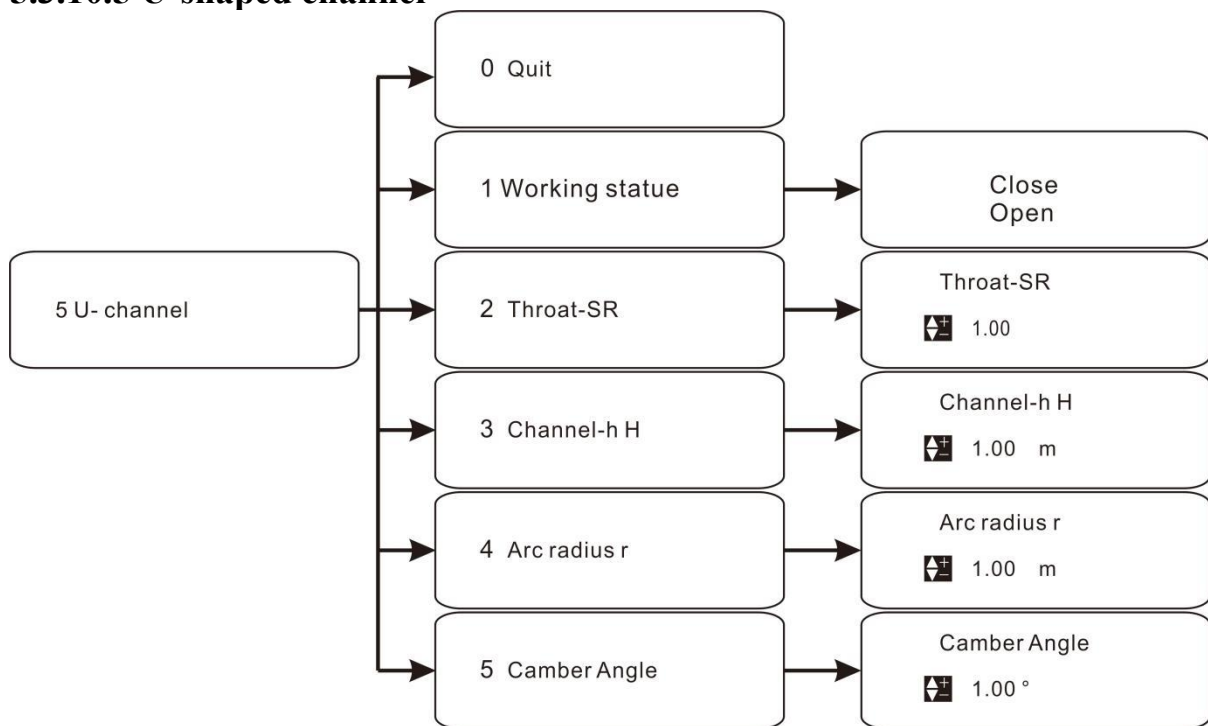

**Working status:** off, indicating that parabolic channel is not selected;  
on, indicating it is selected.

**Throat-SR:** The shrinkage ratio of water weir throat section to channel area.

**Channel-h H:** The vertical height from the bottom of the channel to the top of the channel.

**Arc radius r:** radius of U-shaped channel bottom arc.

**Camber Angle:** angle of inclination of two side walls of U-shaped channels.

The following is a section of U-shaped flume.

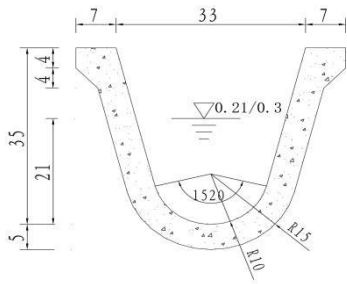

Section of U30 channel

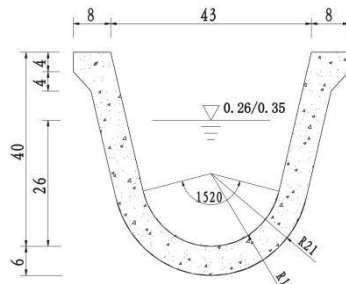

Section of U40 channel

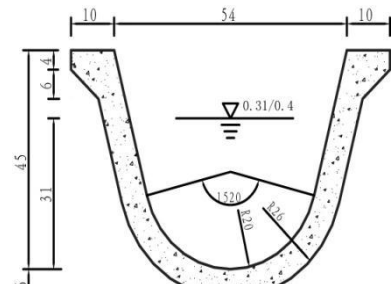

Section of U50 channel

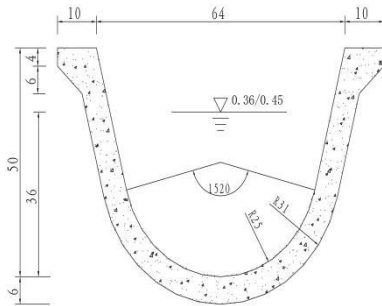

Section of U60 channel

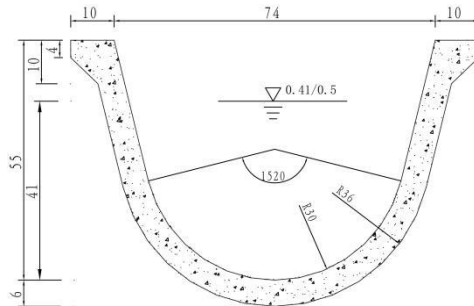

Section of U70 channel

**5.3.10.6 Channel or flume:**

**5.3.10.6.1 Roughness coefficient n:** roughness coefficient value n, "roughness coefficient" in short.

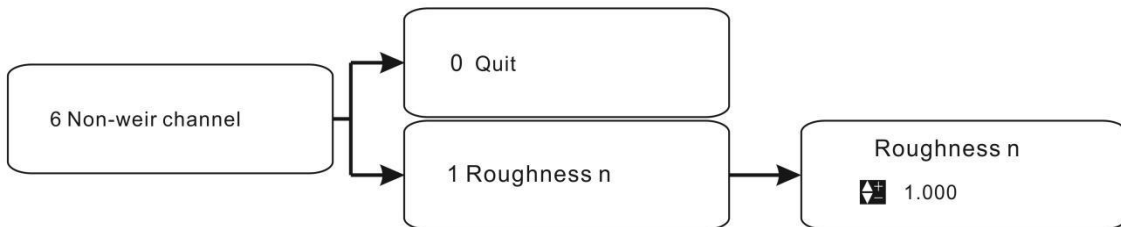

See the roughness coefficient of the pipes, channels and rivers on site in the table below.

Roughness coefficient n of artificial pipeline

Type of pipeline	Value n
Vitrified clay pipe (with glaze)	0.013
Concrete and reinforced concrete rain pipes	0.013
Concrete and reinforced concrete sewage pipes	0.014
Asbestos cement pipe	0.012
Cast iron pipe	0.013
Steel pipe	0.012

Roughness coefficient n of artificial channel

Channel type	Value n
Channel plastered with cement mortar	0.013
Brick channels (no plastering)	0.015
Mortar block stone channel (no plastering)	0.017
Dry-laid rubble channel	0.020~0.025
Soil open channel (including those with turf)	0.025~0.030
Wooden flume	0.012~0.014

Rough coefficient value n of drainage channel

Drainage channel	Wall condition			
	Excellent	Good	Ordinary	Bad
Regular-shaped soil channels	0.017	0.020	0.0225	0.025
Curved and gentle soil channel	0.0225	0.025	0.0275	0.030
Soil channel excavated by an excavator	0.025	0.0275	0.030	0.033
Regular and clean chisel channel	0.025	0.030	0.033	0.035
Channel with an earthy stone bank	0.028	0.030	0.033	0.035
Channel with a bank full of weed under the gravel	0.025	0.030	0.035	0.040
Channel with an irregular cross section in the rock	0.035	0.040	0.045	

Roughness coefficient n of natural river bed

Natural river bed	Wall condition			
	Excellent	Good	Ordinary	Bad
Clean and straight river beds without collapse or deep pits	0.025	0.0275	0.030	0.033
River beds same as above, but with pebbles and weeds	0.030	0.033	0.035	0.040
Curved river beds with some pits or shoals	0.033	0.035	0.040	0.045
River beds same as above, but with pebbles and weeds	0.035	0.040	0.045	0.050
River beds same as above, but with small downstream slope and effective section	0.040	0.045	0.050	0.055
Curve river beds with pits, shoals, weeds and pebbles, and river reaches with pebbles	0.045	0.050	0.055	0.060
River reaches with weeds, deep holes and slow current	0.050	0.060	0.070	0.080

River reaches overgrown with weeds	0.075	0.100	0.125	0.150
------------------------------------	-------	-------	-------	-------

**5.3.10.6.2 Slope i:** Slope is the degree of steepness of the surface element, and the ratio of the vertical height  $h$  to the horizontal distance  $l$  of the slope is usually referred to as the slope (or slope ratio), indicated as  $i$ .



**5.3.10.7 Rectangular channel:**

**Working status:** off, indicating that the rectangular channel is not selected; on, indicating that it is selected.

**Width  $b$ :** it is the entire width of the channel, in meters.

**Channel height  $H$ :** it is the distance from the top of the channel to the bottom of the channel, in meters.

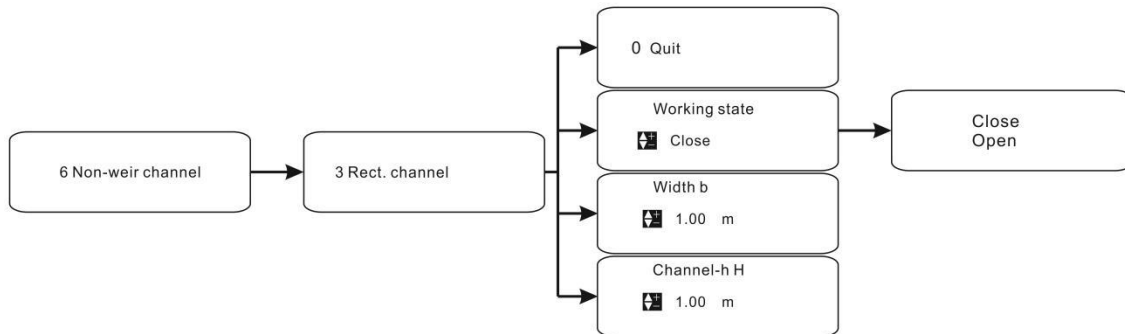

**5.3.10.8 Trapezoidal channel**

**Working status:** off, indicating that the trapezoidal channel is not selected; on, indicating that it is selected.

**Maximum water surface width  $B$ :** it is the horizontal distance between the banks at the top of the channel, in meters.

**Bottom width  $b$ :** it is the width of the bottom of the channel in meters.

**Channel height:** it is the distance from the top of the channel to the bottom of the channel, in meters.

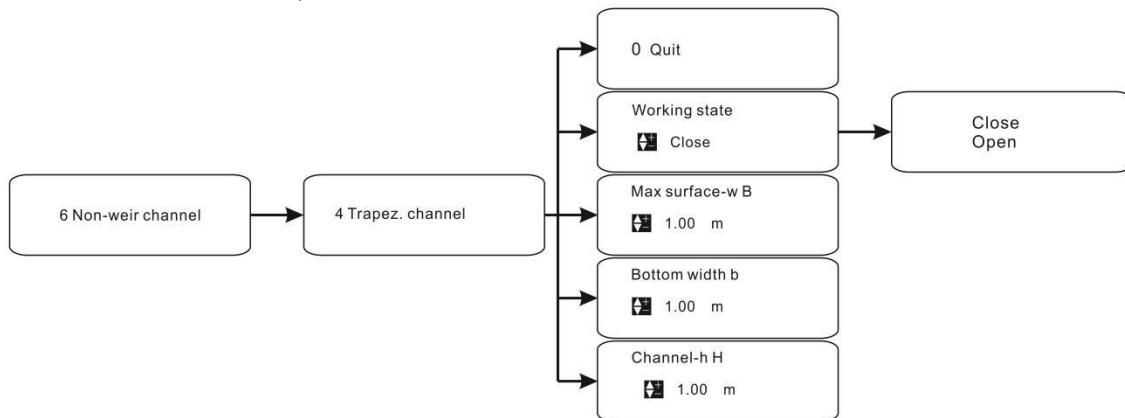

**5.3.10.9 Circular channel**

**Working status:** off, indicating that the circular channel is not selected; on,

indicating that it is selected.

**Circular radius r:** it is the radius of the circle, in meters.

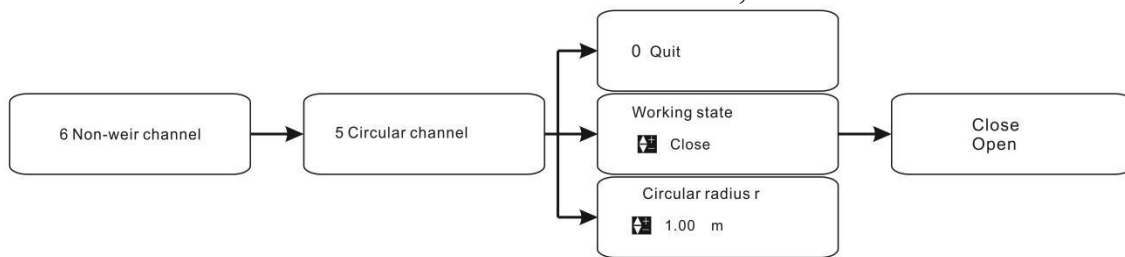

### 5.3.10.10 Parabolic channel

**Working status:** off, indicating that parabolic channel is not selected;  
on, indicating it is selected.

**Maximum water surface width B:** The maximum channel width is at the measuring point.

**Channel height:** The height from the bottom of the channel to the top of the channel.

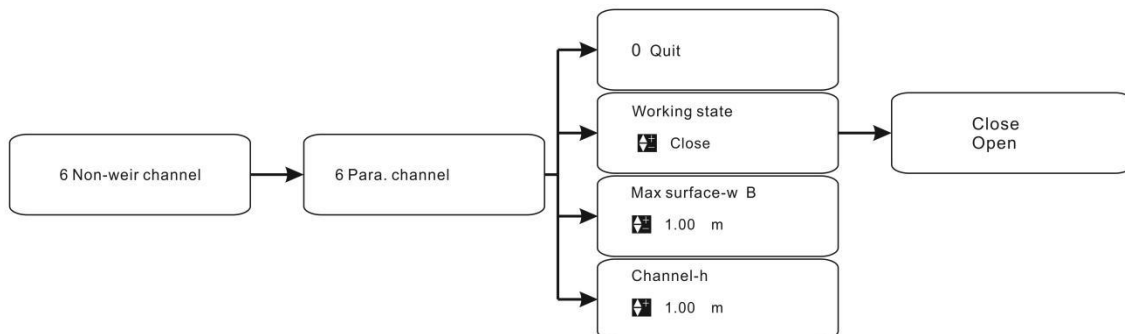

### 5.3.11 "10 Other parameters"

**20mA flow value:** 20mA flow value setting, indicating the instantaneous flow value corresponding to the output of 20mA. The factory setting defaults to maximum flow.

**4mA flow value:** 4mA flow value setting, indicating the instantaneous flow value corresponding to the output of 4mA. The factory setting defaults to 0.

**Accumulative flow:** it is used to copy the cumulative water volume when the meter is replaced. The factory setting defaults to 0.

**Water yield reset:** it is used to reset the water volume.

**Flow unit:** The flow rate display unit can be changed, "m<sup>3</sup>/h" indicates cubic meter per hour, "l/s" indicates litre per second, and "m<sup>3</sup>/s" indicates "cubic meter per second. The factory setting defaults to "m<sup>3</sup>/h".

**Interface switch:** It can switch between flow display interface and liquid level display interface.

**Current output:** 600Ω for 4~20mA resistance load capacity. When it is used for flowmeter, 4 ~ 20mA shall be output according to instantaneous flow; and when it is used for liquid level meter, 4~20mA shall be output according to the liquid level. The factory setting defaults to flow output.

**Accumulative flow units:** there are two units, "L" and "m<sup>3</sup>".

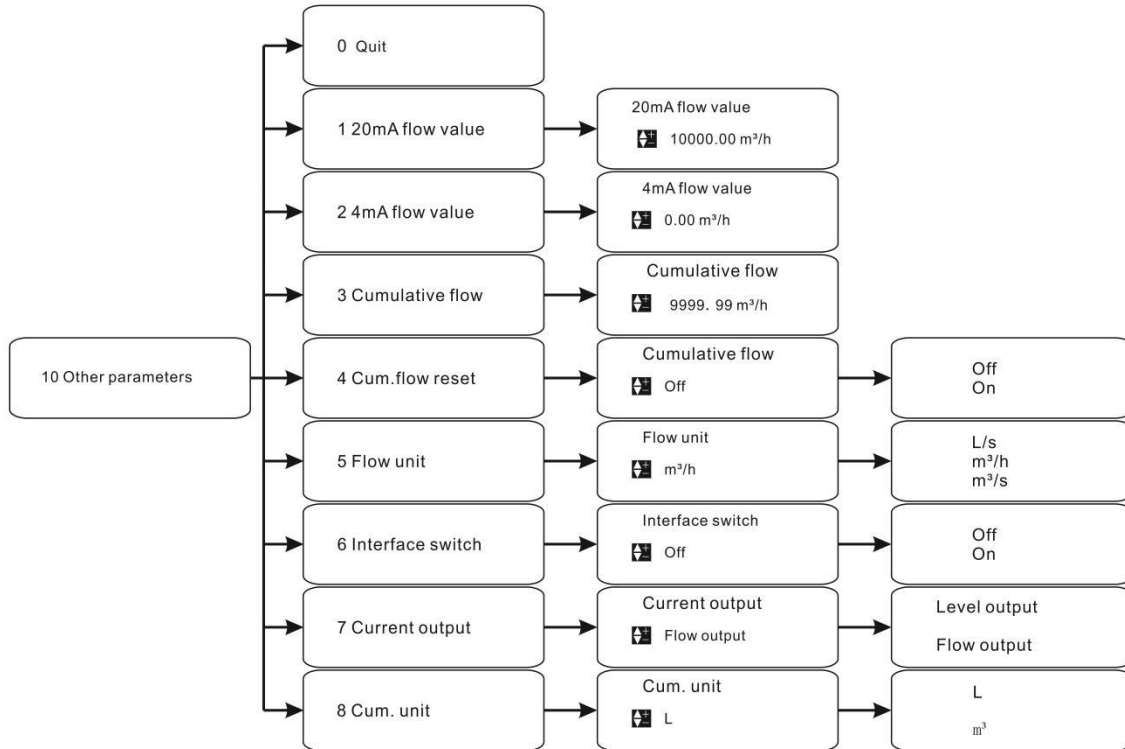

### 5.3.12 "11 Benchmark selection"

**Benchmark selection:** Yes: It is used to calibrate the measurement accuracy. No: It is not used to calibrate the measurement accuracy. Factory setting is defaulted as "No".

**Calibration:** When the benchmark is selected to calibrate the measurement accuracy, it shall be calibrated first, and the measurement value from the bottom surface of the probe to the upper surface of the benchmark can be input into this menu.

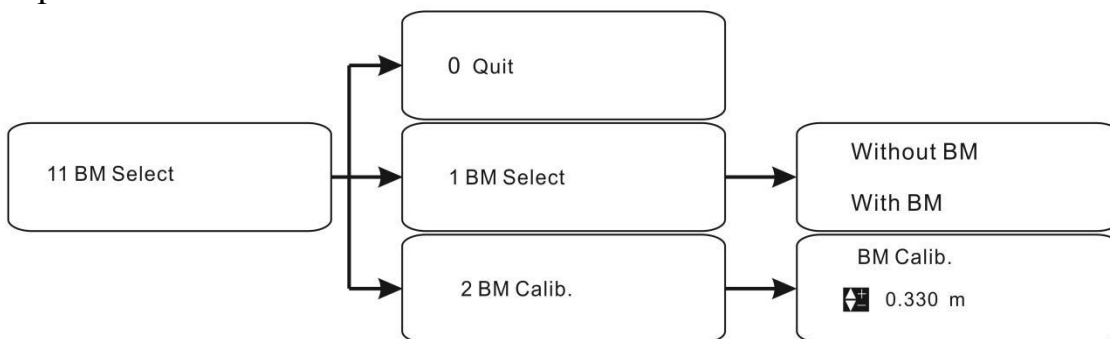

### 5.3.13 "12 Reset"

**Factory reset:** Yes, reset to the factory setting. No: exit. Factory setting is defaulted as "No".

**System reset:** Yes: reset the system setting. No: exit. Factory setting is defaulted as "No". **(Please do not modify it, it is for factory set)**

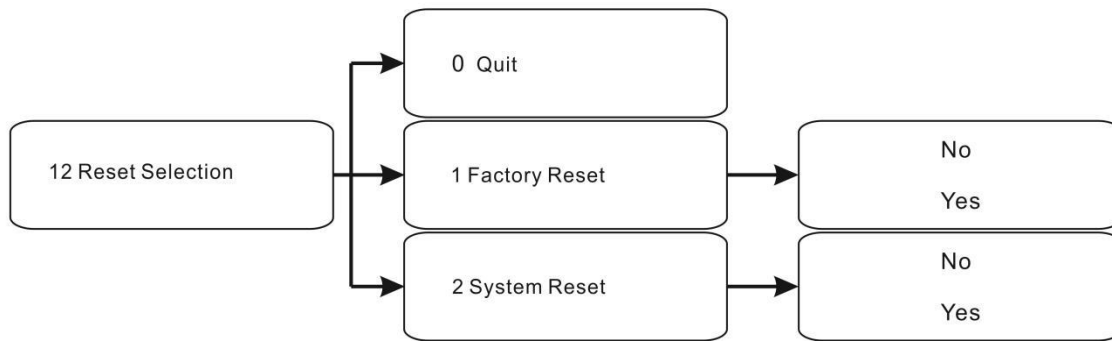

## VI. Main functions

### 6.1 Liquid Level Measurement

### 6.2 Open Channel Flow Measurement

It is adopted for right triangle weir, rectangle weir, trapezoidal weir, Parshall flume, parabolic weir and channel without weir or flume.

### 6.3 4~20mA remote current output

600Ω for 4~20mA resistance load capacity. When it is used for flowmeter, 4 ~ 20mA shall be output according to the flow; and when it is used for liquid level meter, it shall be output according to the liquid level. 4mA corresponds to the zero value of liquid level or flow; The corresponding value of 20mA can be set in the "20mA current value" of the "parameter setting" menu.

### 6.4 Single-pole Double-throw Relay

AC 250V/ 8A or DC 30V/ 5A relay is used, and the status can be programmed. One relay is used to limit the size of the instantaneous flow, and the other relay is used for the cumulative flow proportional output, that is, the relay is closed once through each preset cumulative flow.

### 6.5 Memory Space

The maximum accumulative water flow measured by this meter can reach 12 digits (including 2 decimals). When the accumulative flow reaches 4290000000.00t, it will reset automatically for new accumulation. The maximum instantaneous flow rate can reach 99999.99t/h.

## VII. Measuring weir and flume

In terms of the selection, the size of the flow in the channel, the water regime in the channel, and the condition to form the free flow shall be considered. According to the maximum flow, we can choose different weirs and flumes.

Free flow: Generally speaking, water can flow through rectangular weir, triangular weir and Parshall flume smoothly without any retention, and the downstream water will not be full.

Right triangle weir is recommended when the maximum flow is less than

40L/s;

Parshall flume is recommended when the maximum flow is greater than 40 L/s;

Rectangular weir is recommended when the upstream channel is short and the maximum flow is greater than 40L/s.

It is better to choose the Parshall flume, if may. The relationship between water level and flow rate of Parshall flumes are measured in the laboratory, and the requirements for upstream channel conditions are weak. The relationship between water level and flow rate of triangular weir and rectangular weir are obtained by theoretical calculation, with some errors.

The measuring weirs or flumes made of fiberglass shall be adopted. The weir crest size of triangle weirs and rectangular weirs shall be accurate, and the side toward the water intake shall be smooth; the size of the throat part of Parshall flume shall be accurate and the flume surface shall be smooth.

### 7.1 Right triangle weir

The following diagram is a processing drawing of a right triangle weir. If to adopt the above right triangle weir, the operator can select "open" in "9 Type of weirs and flumes" on the menu → "1 Right triangle weir" → "1 Working status". Then, the corresponding flow rate can be calculated with the meter according to the water level.

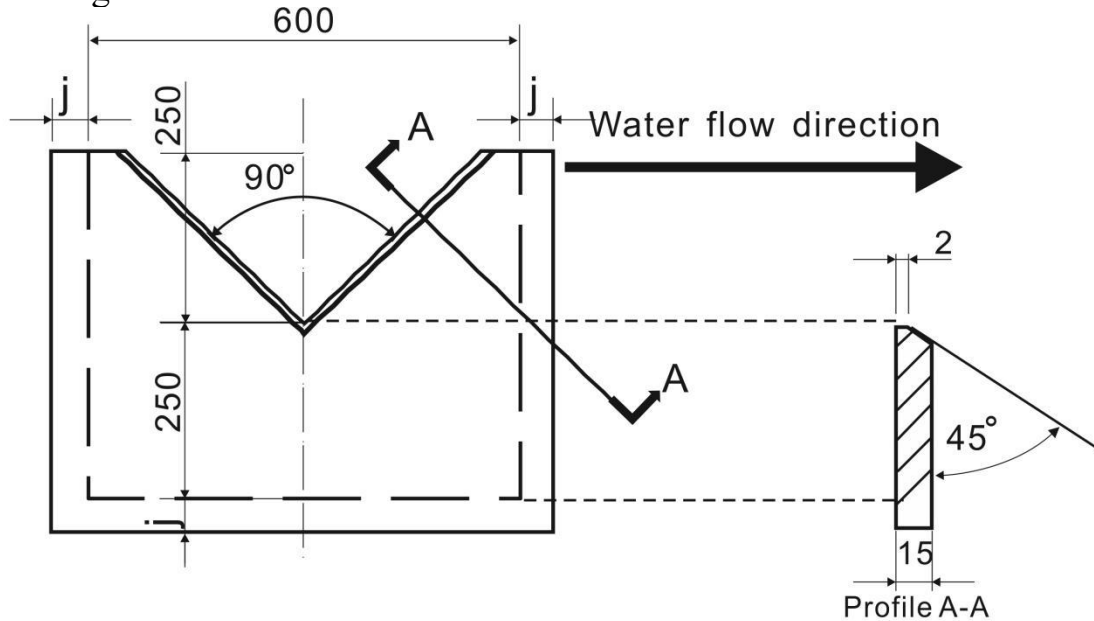

Materials: fiberglass, PVC or stainless steel

1. The appearance shall be smooth and flat without warp;
2. The edge of the triangular opening shall be straight and smooth;
3. j: It is the part with the side and bottom embedded into the side wall of the channel. The size is determined by the installation site.
4. The default opening is 90 degrees, and there are 60 degrees and 30 degrees

The triangular weir shall be installed on the channel as shown below. The

weir plate shall be vertically installed on the axis of the channel. When the triangular weir is processed, the apex angle can be rounded. When determining the zero position of the water level, it should be noted that the zero point of the water level of the triangular weir shall be at the intersection point of the extension line on the side of the triangular weir. The probe of the meter shall be installed on the upstream 0.5~1m from the weir plate.

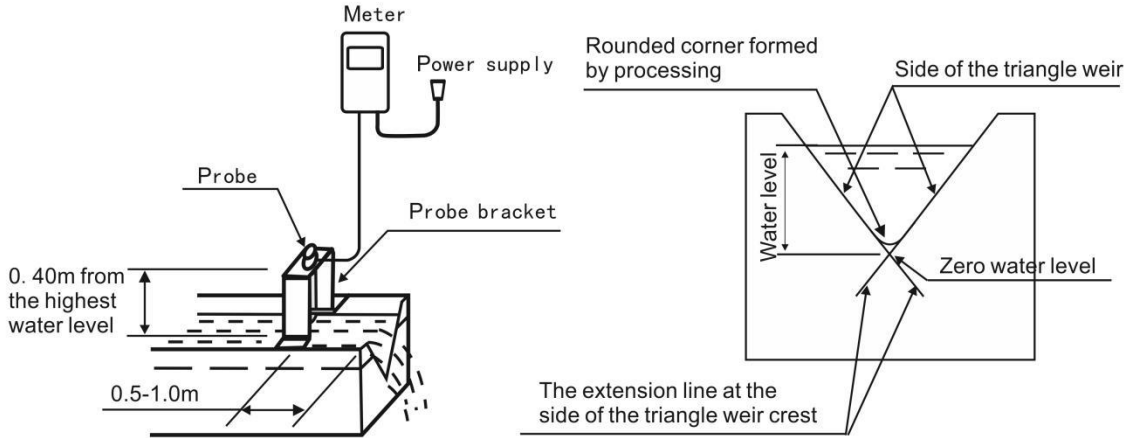

## 7.2 Rectangular Weir

The rectangular weir can be processed according to Fig. 7.2.1. The relationship between water level and flow rate of rectangular weir mainly depends on the weir crest width  $b$ . It is also related to the width of upstream channel "B" and the height of weir ridge "p". If to adopt rectangular weir shown in Fig. 6.2.1, the operator can select "open" in "9 Type of weirs and flumes" on the menu → "2 Rectangular weir" → "1 Working status", and then select a value of "0.25m, 0.50m, 0.75m, 1.00m, non-standard channel" in "2 Standard channel", and the meter can calculate the flow rate according to the water level automatically.

Rectangular weir shall be installed on the channel as shown in Fig. The weir plate shall be vertically installed on the axis of the channel. The probe of the meter shall be installed on the upstream, 0.5~1m to the weir plate.

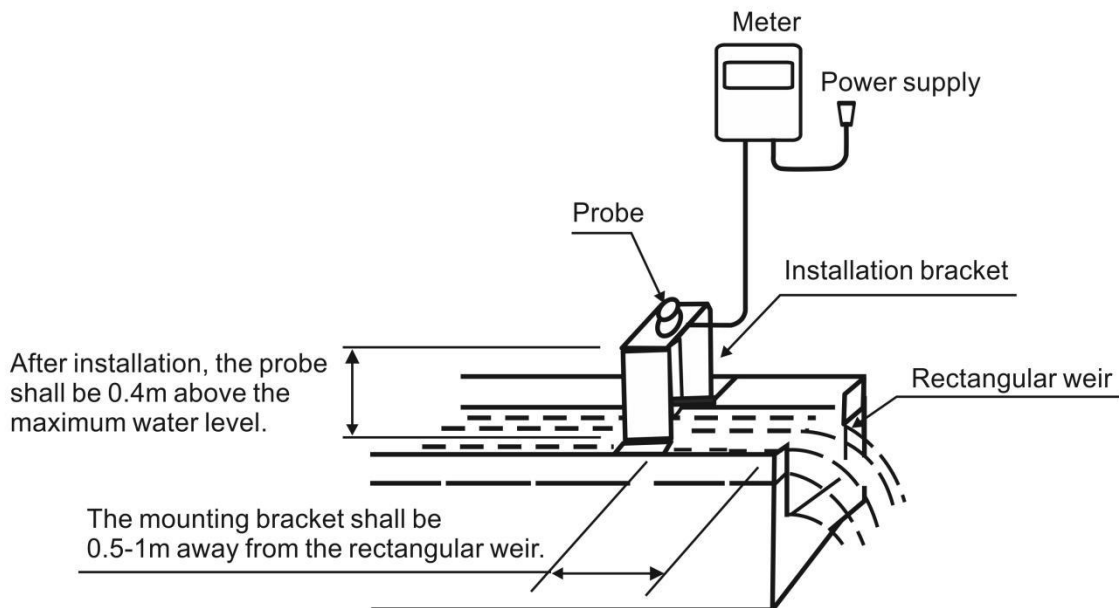

The crest width of rectangular weir on site may exceed 1.00m. At this time, the non-standard rectangular weir shall be used to measure. If this meter already has this function, the operator may input values  $b$ ,  $B$  and  $P$  measured on site according to the non-standard rectangular weir, and then start the measurement.

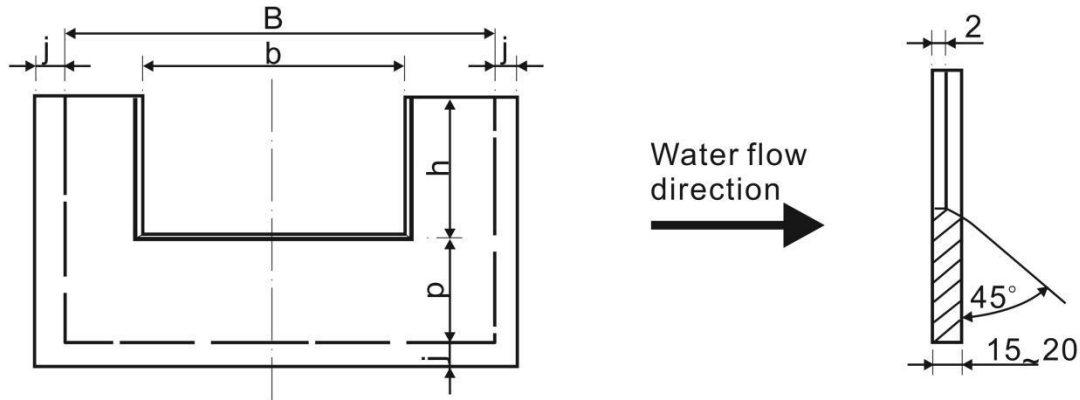

Materials: fiberglass, PVC or stainless steel.

1. The surface shall be smooth and flat without wrap;
2. The edge of the rectangular weir crest shall be flat and smooth.
3.  $j$ : it is the part embedded into the side wall and bottom during installation, which is determined according to the site conditions.
4.  $b$  = weir crest width;  $B$  = width of upstream channel;  
 $H$  = liquid level height;  $P$  = height of weir wall;

The dimensions of  $b$ ,  $B$ ,  $h$  and  $p$  in the figure are shown in the following table (unit: mm):

$b=250$	$B=500$	$h=250$	$p=100$
---------	---------	---------	---------

$b=750$	$B=1000$	$h=500$	$p=200$
---------	----------	---------	---------

$b=500$	$B=800$	$h=300$	$p=150$
---------	---------	---------	---------

$b=1000$	$B=1500$	$h=500$	$p=200$
----------	----------	---------	---------

### 7.3 Trapezoidal Weir

If to adopt trapezoidal weir, the operator can select "open" in "9 Type of weirs and flumes" on the menu → "2 Rectangular weir" → "1 Working status", and then input the actual weir sill width of the channel in "2 Weir sill width  $B$ ", and the meter can calculate the flow rate according to the water level automatically. The installation of trapezoidal weir is the same as that of rectangular weir.

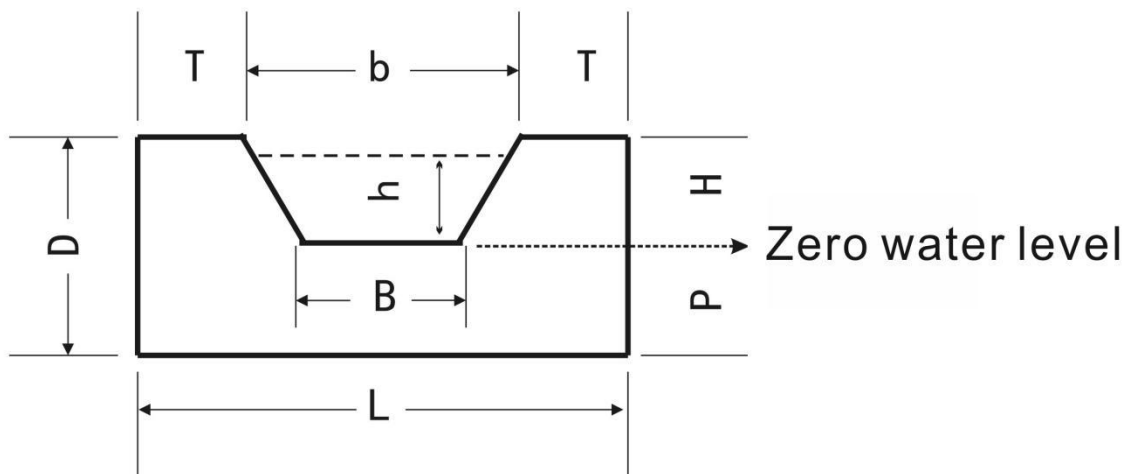

## 7.4 Parshall Flume

The structure of the Parshall flume is shown in Fig. The marked size of the Parshall flume is the throat width "b". First of all, according to the maximum flow required, a proper throat width "b" of the Parshall flume can be found from the "Schedule II water level - flow formula of Parshall flume". Then, other dimensions of the Parshall flume corresponding to throat width equal to "b" can be found from the "Schedule I Structural Dimensions of Parshall Flume", such as "L1", "La", "L" and "L2".

Fill the sizes into drawing of Parshall flume for processing. The installation position on channel is shown as figure below.

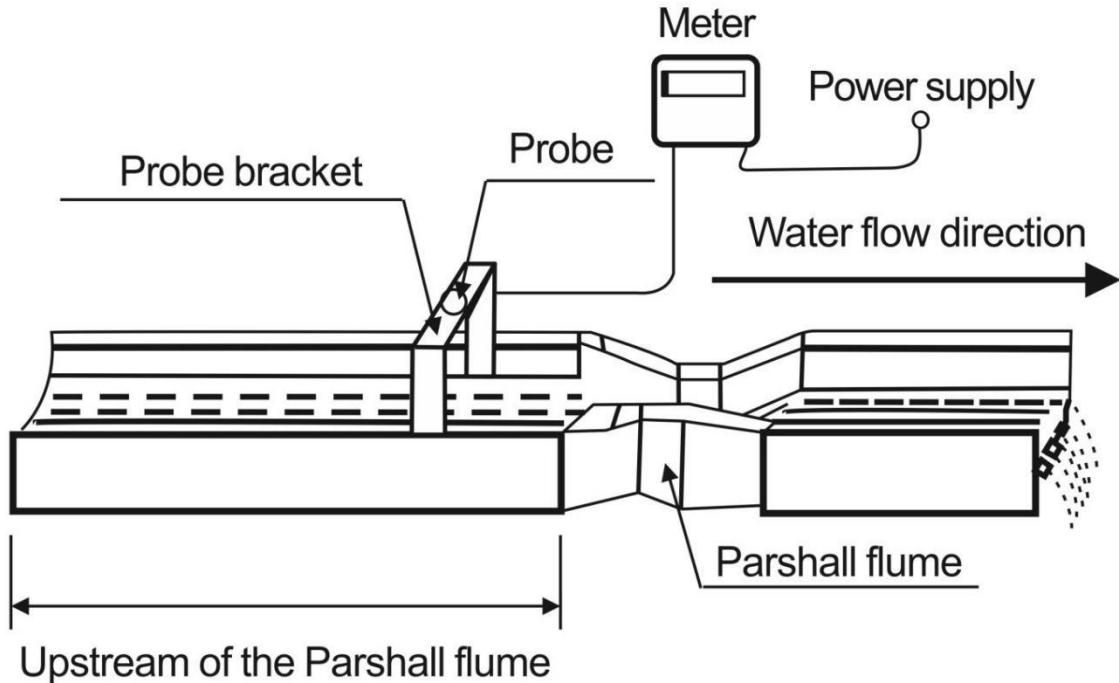

The water level - flow relationship of the Parshall flume is generally like:  $Q=Ca^n$ . According to the throat wide "b", the repair work coefficient c and exponent n can be found out from "Schedule II Parshall Flume Water Level - Flow Formula", and the operator can select the menu "9 Type of weirs and flumes" → "4 Parshall flume", and input "2 Repair work coefficient c and "3 Index n". Then, the meter can automatically calculate the flow rate corresponding to the water level.

It is applicable to the structural map of No. 1-4 Parshall flumes, as shown below:

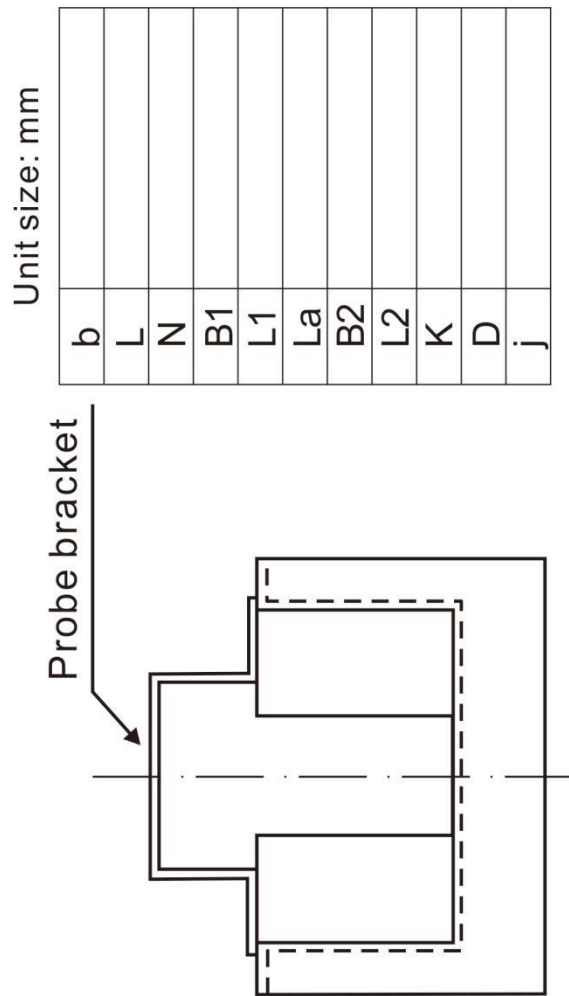

Unit size: mm

b
L
N
B1
L1
La
B2
L2
K
D
j

Description:

Materials: fiberglass, PVC or stainless steel

1. Internal dimensions shall be accurate.
2. The inner surface shall be smooth and flat;
3. Wall thickness shall be greater than 8mm;
4. If the span of the probe bracket is too large, the strength shall be increased;
5. The distance from the bracket to the highest water level shall be **>200mm**;
6. The value j is related to the installation on the channel and is determined according to the site conditions.

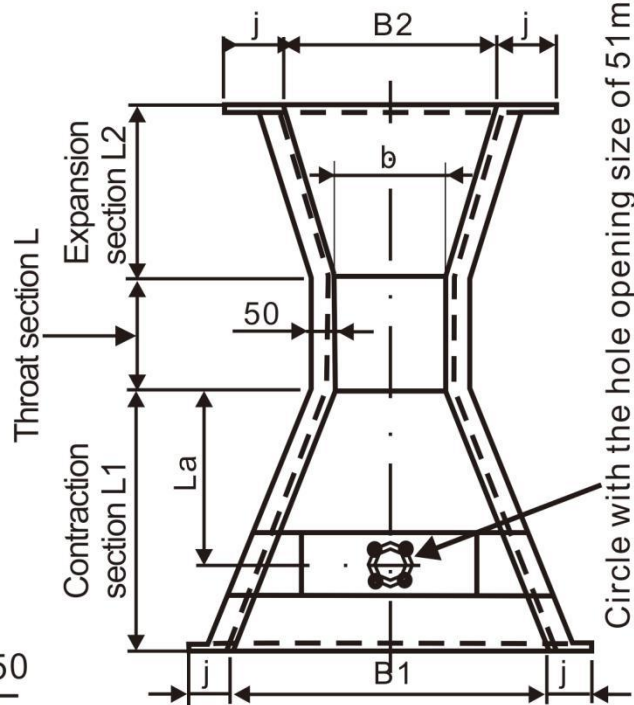
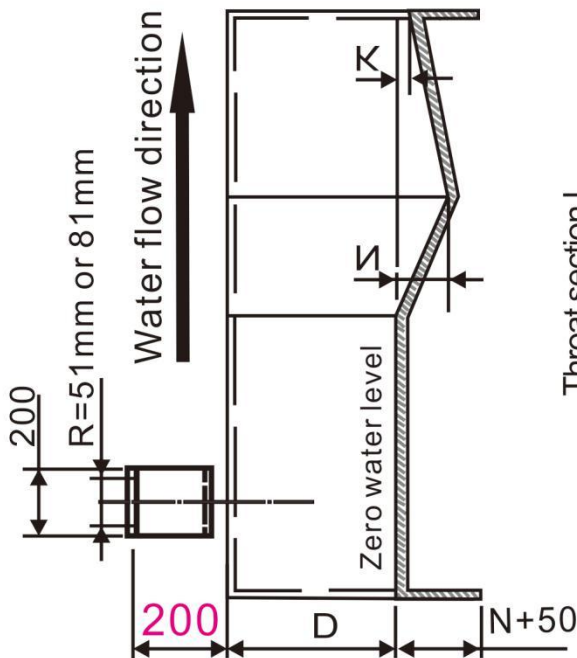



## VIII. Errors and Handling

Phenomena	Cause	Solution
No display of flowmeter	<ol style="list-style-type: none"> <li>1. Poor connection of the power supply</li> <li>2. Poor contact of the LCD</li> <li>3. Damaged LCD</li> </ol>	<ol style="list-style-type: none"> <li>1. Check the power cord and measure the voltage with the multimeter.</li> <li>2. Replug the LCD and its wiring.</li> <li>3. Return to factory for LCD replacement</li> </ol>
Enter the liquid level display interface. If there is no change in the small horn symbol on the screen shown as "▲", it indicates that the system is in the wave loss status.	<ol style="list-style-type: none"> <li>1. The measured distance exceeding the flowmeter range</li> <li>2. Strong disturbance, wave and agitation of the measured medium</li> <li>3. Strong interference sources around, such as inverter and motor</li> <li>4. Probe not aligned with the surface to be measured.</li> <li>5. There are obstacles in the measured space, such as support rod and feeding port.</li> <li>6. The liquid level in blind area</li> <li>7. The ultrasonic wave is reflected to other areas, for the measured surface is inclined.</li> </ol>	<ol style="list-style-type: none"> <li>1. Consider replacing it with flowmeters with larger ranges.</li> <li>2. The equipment will automatically return to normal measurements after the measured medium recovers. Or use 150m wave guide tubes to install the flowmeter.</li> <li>3. Ground the flowmeter and isolate the power source and the output signal line.</li> <li>4. Recalibrate the probe, and it shall be perpendicular to the measured surface.</li> <li>5. Re-select the appropriate installation location to avoid interference as far as possible.</li> <li>6. Raise the installation height of the probe, and the installation height of the probe transmitter surface is <math>&gt;</math> maximum surface + blind area.</li> <li>7. Modify the installation method, or measure after the liquid level covers the slope.</li> </ol>
The measured data fluctuated	<ol style="list-style-type: none"> <li>1. Large fluctuation on water surface</li> </ol>	<ol style="list-style-type: none"> <li>1. Install on somewhere flat and stable.</li> </ol>

<p>wildly.</p>	<p>2.Electromagnetic interference from power supply</p> <p>3.Inverter interference</p> <p>4.False surface reflection target encountered by ultrasonic wave</p> <p>5.The ultrasonic wave in blind area</p> <p>6.Connection error between probe and host</p>	<p>2.Replace the power supply, or switch to isolated power supply.</p> <p>3.Ground the host independently and reliably and keep it away from the frequency converter.</p> <p>4.Replace the installation position to ensure that the ultrasonic wave emitted by the probe will not hit both sides of the channel and other obstacles.</p> <p>5.Lift the probe to make the highest water level not enter the blind area.</p> <p>6.Rewire according to instructions. Pay attention to the wiring sequence if the extension line is added, and connect the shielding layer of the wire.</p>
----------------	--	---

## IX. Structural dimension of the Parshall flume

Unit: m

Category	S/N	Throat section			Contraction section			Expansion section			Wall height
		b	L	N	B1	L1	La	B2	L2	K	D
Small size	1	0.025	0.076	0.029	0.167	0.356	0.237	0.093	0.203	0.019	0.23
	2	0.051	0.114	0.043	0.214	0.406	0.271	0.135	0.254	0.022	0.26
	3	0.076	0.152	0.057	0.259	0.457	0.305	0.178	0.305	0.025	0.46
	4	0.152	0.305	0.114	0.400	0.610	0.407	0.394	0.610	0.076	0.61
	5	0.228	0.305	0.114	0.575	0.864	0.576	0.381	0.457	0.076	0.77
Standard size	6	0.25	0.60	0.23	0.78	1.325	0.883	0.55	0.92	0.08	0.80
	7	0.30	0.60	0.23	0.84	1.350	0.902	0.60	0.92	0.08	0.95
	8	0.45	0.60	0.23	1.02	1.425	0.948	0.75	0.92	0.08	0.95
	9	0.60	0.60	0.23	1.20	1.500	1.0	0.90	0.92	0.08	0.95
	10	0.75	0.60	0.23	1.38	1.575	1.053	1.05	0.92	0.08	0.95
	11	0.90	0.60	0.23	1.56	1.650	1.099	1.20	0.92	0.08	0.95
	12	1.00	0.60	0.23	1.68	1.705	1.139	1.30	0.92	0.08	1.0
	13	1.20	0.60	0.23	1.92	1.800	1.203	1.50	0.92	0.08	1.0
	14	1.50	0.60	0.23	2.28	1.95	1.303	1.80	0.92	0.08	1.0
	15	1.80	0.60	0.23	2.64	2.10	1.399	2.10	0.92	0.08	1.0
	16	2.10	0.60	0.23	3.00	2.25	1.504	2.40	0.92	0.08	1.0
	17	2.40	0.60	0.23	3.36	2.40	1.604	2.70	0.92	0.08	1.0
Large size	18	3.05	0.91	0.343	4.76	4.27	1.794	3.68	1.83	0.152	1.22
	19	3.66	0.91	0.343	5.61	4.88	1.991	4.47	2.44	0.152	1.52
	20	4.57	1.22	0.457	7.62	7.62	2.295	5.59	3.05	0.229	1.83
	21	6.10	1.83	0.686	9.14	7.62	2.785	7.32	3.66	0.305	2.13
	22	7.62	1.83	0.686	10.67	7.62	3.383	8.94	3.96	0.305	2.13
	23	9.14	1.83	0.686	12.31	7.93	3.785	10.57	4.27	0.305	2.13
	24	12.19	1.83	0.686	15.48	8.23	4.785	13.82	4.88	0.305	2.13
	25	15.24	1.83	0.686	18.53	8.23	5.776	17.27	6.10	0.305	2.13

## X. Water level - flow formula of Parshall flume

Category	S/ N	Throat width b(m)	Flow formula $Q=Cha^n$ (L/S)	Level range h(m)		Flow range Q(L/S)		Critical submerg ence %
				Minimum	Maximum	Minimum	Maximum	
Small size	1	0.025	<b>60.4ha<sup>1.55</sup></b>	0.015	0.21	0.09	5.4	0.5
	2	0.051	<b>120.7ha<sup>1.55</sup></b>	0.015	0.24	0.18	13.2	0.5
	3	0.076	<b>177.1ha<sup>1.55</sup></b>	0.03	0.33	0.77	32.1	0.5
	4	0.152	<b>381.2ha<sup>1.53</sup></b>	0.03	0.45	1.50	111.0	0.6
	5	0.228	<b>535.4ha<sup>1.53</sup></b>	0.03	0.60	2.5	251	0.6
Stand ard size	6	0.25	<b>561ha<sup>1.513</sup></b>	0.03	0.60	3.0	250	0.6
	7	0.30	<b>679ha<sup>1.521</sup></b>	0.03	0.75	3.5	400	0.6
	8	0.45	<b>1038ha<sup>1.537</sup></b>	0.03	0.75	4.5	630	0.6
	9	0.60	<b>1403ha<sup>1.548</sup></b>	0.05	0.75	12.5	850	0.6
	10	0.75	<b>1772ha<sup>1.557</sup></b>	0.06	0.75	25.0	1100	0.6
	11	0.90	<b>2147ha<sup>1.565</sup></b>	0.06	0.75	30.0	1250	0.6
	12	1.00	<b>2397ha<sup>1.569</sup></b>	0.06	0.80	30.0	1500	0.7
	13	1.20	<b>2904ha<sup>1.577</sup></b>	0.06	0.80	35.0	2000	0.7
	14	1.50	<b>3668ha<sup>1.586</sup></b>	0.06	0.80	45.0	2500	0.7
	15	1.80	<b>4440ha<sup>1.593</sup></b>	0.08	0.80	80.0	3000	0.7
	16	2.10	<b>5222ha<sup>1.599</sup></b>	0.08	0.80	95.0	3600	0.7
Large size	17	2.40	<b>6004ha<sup>1.605</sup></b>	0.08	0.80	100.0	4000	0.7
	18	3.05	<b>7463ha<sup>1.6</sup></b>	0.09	1.07	160.0	8280	0.8
	19	3.66	<b>8859ha<sup>1.6</sup></b>	0.09	1.37	190.0	14680	0.8
	20	4.57	<b>10960ha<sup>1.6</sup></b>	0.09	1.67	230.0	25040	0.8
	21	6.10	<b>14450ha<sup>1.6</sup></b>	0.09	1.83	310.0	37970	0.8
	22	7.62	<b>17940ha<sup>1.6</sup></b>	0.09	1.83	380.0	47160	0.8
	23	9.14	<b>21440ha<sup>1.6</sup></b>	0.09	1.83	460.0	56330	0.8
	24	12.19	<b>28430ha<sup>1.6</sup></b>	0.09	1.83	600.0	74700	0.8
	25	15.24	<b>35410ha<sup>1.6</sup></b>	0.09	1.83	750.0	93040	0.8

**Description: Repair work coefficient "C" and index "N". Taking serial number 1 (flume 1) as an example, repair work coefficient C is: 60.4, and index N is: 1.55.**

## XI. Ultrasonic Open Channel Flowmeter MODBUS Communication Protocol Version V1.4

11.1 The hardware is adopted with RS-485, master-slave half-duplex communication, that is, the host calls the slave address, and the slave answers.

11.2 Data frame: 10 digits, 1 start bit, 8 data bits and 1 stop bit, without verification.

Baud rate: 1200, 2400, 4800 and 9600 (9600 by default).

11.3 Function code 03H: Read register value

Sending from the host:

1	2	3	4	5
ADR	03H	High-order byte of initial register	Low-order byte of initial register	High-order byte of register number

6	7	8
Low-order byte of register number	Low-order byte of CRC code	High-order byte of CRC code

The first byte, ADR: address of slave machine (=001~254)

The second byte 03H: Read the register value function code

The third and fourth bytes: the start address of the register to be read

The fifth and sixth bytes: the number of the register to be read

The seventh and eighth bytes: CRC16 verification from byte 1 to byte 6

When the slave machine receives correctly, it will send back following values:

1	2	3	4、5	6、7	
ADR	03H	Total number of bytes	Register data 1	Register data 2	...

	M-1、M	M+1	M+2
...	Register data M	Low-order byte of CRC code	High-order byte of CRC code

The first byte, ADR: address of slave machine (=001~254)

The second byte 03H: Return to read function code

The third byte: Total number of bytes from 4 to M (included)

Byte from 4 to M: Register data

The M+1 and M+2 bytes: CRC16 verification from byte 1 to byte M

11.4 Reading of "Water Level" Measured by Open Channel Flowmeter.

Send instruction: 01 03 00 00 00 02 C4 0B

Return: 1 03 04 40 26 14 7B C6 3F

01: it indicates the 485 address of the slave machine.

03: it indicates the function "Return read data".

04: it indicates that the register data returned have 4 bytes.

40 26 14 7B: it indicates the returned register data. Here is the "floating number", and it cannot be converted directly to decimal data. Instead, the "floating number converter" shall be used to convert the hexadecimal floating number to decimal number.

Operation process: Download "single-precision floating number converter" first, click to run the software, the following screen will display:

Enter the returned value "40 26 14 7B" into "hexadecimal number".

Click the button of "convert from hexadecimal".

Then, the decimal number calculated from the hexadecimal floating number is:

Compare 2.5950000 with the "water level" displayed on the LCD of the open channel flowmeter:

It is correct if two numbers correspond with each other.

Namely, the water level value read by 485 is the same as the that measured by the ultrasonic open channel flowmeter.

### 11.5 Reading of the Integral Part of the "Accumulative Flow" Measured by the Open Channel Flowmeter.

Send instruction: 01 03 00 04 00 02 85 CA

Return: 01 03 04 00 06 97 9E 79 FD

01: it indicates the 485 address of the slave machine.

03: it indicates the function "Return read data".

04: it indicates that the register data returned have 4 bytes.

00 06 97 9E: it indicates the returned register data. The "long integer" hexadecimal number here can be converted directly to a decimal number.

Operation process:

Open "calculator" in Win10 first.

Click the top left corner of the software and the following will display:

Click "programmer" in the drop-down menu.

Click "HEX" to enter a hexadecimal number:

Input 0006979E. There is no space between numbers. The "DEC" means a "decimal" number, and the conversion from "0006979E" to "decimal" is "432030".

Compare 432030 with the "Accumulative flow" displayed on the LCD of the open channel flowmeter:

It shall be noted that it is the integral part of the "Accumulative flow". The decimal part of the "Accumulative flow" value shall be read separately.

When the slave machine does not receive correctly, it will send back

following values:

1	2	3	4	5
ADR	83H	Information code	Low-order byte of CRC code	High-order byte of CRC code

The first byte, ADR: address of slave machine (=001~254)

The first byte 83H: Register value reading error

The third byte information code: See the table of information code

The fourth and fifth bytes: CRC16 verification from byte 1 to byte 3.

### 11.6 Reading Error of "Water Level" Measured by Open Channel Flowmeter.

Send instruction: 01 03 00 00 00 01 84 0A

Return: 01 83 03 01 31

83: it indicates "register data reading error".

03: it indicates "invalid data value".

### 11.7 Reading Error of "Water Level" Measured by Open Channel Flowmeter.

Send instruction: 01 03 00 0C 00 0D 02 84 0A

Return: 01 83 04 01 31

83: it indicates "register data reading error".

04: it indicates "CRC16 verification error"

### 11.8 Function code 06H: Write a single register data

Sending from the host:

1	2	3	4	5
ADR	06	High-order byte of register address	Low-order byte of register address	High-order byte of data

6	7	8
Low-order byte of data	Low-order byte of CRC code	High-order byte of CRC code

When the slave machine receives correctly, it will send back following values:

1	2	3	4	5
ADR	06	High-order byte of register	Low-order byte of register	High-order byte of data

6	7	8
Low-order byte of data	Low-order byte of CRC code	High-order byte of CRC code

When the slave machine does not receive correctly, it will send back following

values:

1	2	3	4	5
AD R	86 H	Error information code	Low-order byte of CRC code	High-order byte of CRC code

The first byte, ADR: address of slave machine (=001~254)

The first byte 86H: function code of writing error of register number

The third byte information code: See the table of information code

The fourth and fifth bytes: CRC16 verification from byte 1 to byte 3

### 11.9 Function code 10H: Write multiple register numbers in succession

Sending from the host:

1	2	3	4	5	6
ADR	10H	High-order byte of initial register address	Low-order byte of initial register address	High-order byte of register number	Low-order byte of register number

7	8、9	10、11	N、N+1	N+2	N+3
Total number of data bytes	Register data 1	Register data 2	Register data M	Low-order byte of CRC code	High-order byte of CRC code

When the slave machine receives correctly, it will send back following values:

1	2	3	4	5
ADR	10H	High-order byte of initial register address	Low-order byte of initial register address	High-order byte of register number

6	7	8
Low-order byte of register number	Low-order byte of CRC code	High-order byte of CRC code

When the slave machine does not receive correctly, it will send back following values:

1	2	3	4	5
ADR	90H	Error information code	Low-order byte of CRC code	High-order byte of CRC code

The first byte, ADR: address of slave machine (=001~254)

The first byte 90H: function code of writing error of register number

The third byte information code: See the table of information code

The fourth and fifth bytes: CRC16 verification from byte 1 to byte 3

11.10 Register Definition Table: (Note: Register address is coding is hexadecimal.)

Register address	Description	Read Only	Register address	Description	Read Only
0000	Instantaneous value of distance/material level (4-byte floating number, 2 high-order bytes)	√	0001	Instantaneous value of distance/material level (4-byte floating number, 2 low-order bytes)	√
0002	Instantaneous flow rate (4-byte floating number, 2 high-order bytes)	√	0003	Instantaneous flow rate (4-byte floating number, 2 low-order bytes)	√
0004	Integral part of the cumulative flow value (4-byte long integer number, 2 high-order bytes)	√	0005	Integral part of the cumulative flow value (4-byte long integer number, 2 low-order bytes)	√
0006	Decimal part of the cumulative flow value (4-byte floating number, 2 high-order bytes)	√	0007	Decimal part of the cumulative flow value (4-byte floating number, 2 low-order bytes)	√
0008	Simulated output instantaneous value (4-byte floating number, 2 high-order bytes)	√	0009	Simulated output instantaneous value (4-byte floating number, 2 low-order bytes)	√
000A	Instantaneous temperature value (4-byte floating number, 2 high-order bytes)	√	000B	Instantaneous temperature value (4-byte floating number, 2 high-order bytes)	√
000C	Reserved		000D	Reserved	
000E	Reserved		000F	Reserved	
0012	Reserved		0013	Reserved	
0014	Reserved		0015	Reserved	
0016	Reserved		0017	Reserved	
0018	Reserved		0019	Reserved	
001A	Reserved		001B	Reserved	
001C	Reserved		001D	Reserved	
001E	Reserved		001F	Reserved	
0020	Reserved		0021	Reserved	
0022	Alarm value 1 (4-byte floating number, 2 high-order bytes)		0023	Alarm value 1 (4-byte floating number, 2 low-order bytes)	
0024	Alarm return difference value 1 (4-byte floating number, 2 high-order bytes)		0025	Alarm return difference value 1 (4-byte floating number, 2 low-order bytes)	
0026	Alarm value 2 (4-byte floating number, 2 high-order bytes)		0027	Alarm value 2 (4-byte floating number, 2 low-order bytes)	
0028	Alarm return difference value 2 (4-byte floating number, 2 high-order bytes)		0029	Alarm return difference value 2 (4-byte floating number, 2 low-order bytes)	
002A	Alarm value 3 (4-byte floating number, 2 high-order bytes)		002B	Alarm value 3 (4-byte floating number, 2 low-order bytes)	
002C	Alarm return difference value 3 (4-byte floating number, 2 high-order bytes)		002D	Alarm return difference value 3 (4-byte floating number, 2 low-order bytes)	
002E	Alarm value 4 (4-byte floating number, 2 high-order bytes)		002F	Alarm value 4 (4-byte floating number, 2 low-order bytes)	
0030	Alarm return difference value 4 (4-byte floating number, 2 high-order bytes)		0031	Alarm return difference value 4 (4-byte floating number, 2 low-order bytes)	

**Operating Instructions for Ultrasonic Open Channel Flowmeter**

0032	Reference zero (4-byte floating number, 2 high-order bytes)		0033	Reference zero (4-byte floating number, 2 low-order bytes)	
0034	High range point (4-byte floating number, 2 high-order bytes)		0035	High range point (4-byte floating number, 2 low-order bytes)	
0036	Low range point (4-byte floating number, 2 high-order bytes)		0037	Low range point (4-byte floating number, 2 low-order bytes)	
0038	Current setting (4-byte floating number, 2 high-order bytes)		0039	Current setting (4-byte floating number, 2 low-order bytes)	
003A	Blind area setting (4-byte floating number, 2 high-order bytes)		003B	Blind area setting (4-byte floating number, 2 low-order bytes)	
003C	Repair work coefficient c (4-byte floating number, 2 high-order bytes)		003D	Repair work coefficient c (4-byte floating number, 2 low-order bytes)	
003E	Index n (4-byte floating number, 2 high-order bytes)		003F	Index n (4-byte floating number, 2 low-order bytes)	
0040	20mA instantaneous flow value (4-byte floating number, 2 high-order bytes)		0041	20mA instantaneous flow value (4-byte floating number, 2 low-order bytes)	
0042	4mA instantaneous flow rate (4-byte floating number, 2 high-order bytes)		0043	4mA instantaneous flow rate (4-byte floating number, 2 low-order bytes)	
0044	Integral part of accumulated volume (4-byte long integer number, 2 high-order bytes)		0045	Integral part of accumulated volume (4-byte long integer number, 2 low-order bytes)	
0046	Decimal part of accumulated volume (4-byte floating number, 2 high-order bytes)		0047	Decimal part of accumulated volume (4-byte floating number, 2 low-order bytes)	
0048	Weir crest width b (4-byte floating number, 2 high-order bytes)		0049	Weir crest width b (4-byte floating number, 2 low-order bytes)	
004A	Upstream channel width B (4-byte floating number, 2 high-order bytes)		004B	Upstream channel width B (4-byte floating number, 2 low-order bytes)	
004C	Height of weir wall P (4-byte floating number, 2 high-order bytes)		004D	Height of weir wall P (4-byte floating number, 2 low-order bytes)	
004E	Weir sill width (4-byte floating number, 2 high-order bytes)		004F	Weir sill width (4-byte floating number, 2 low-order bytes)	
0050	Throat-SR (4-byte floating number, 2 high-order bytes)		0051	Throat-SR (4-byte floating number, 2 low-order bytes)	
0052	Reserved		0053	Reserved	
0054	Channel-h H (4-byte floating number, 2 high-order bytes)		0055	Channel-h H (4-byte floating num Channel-h Hber, 2 low-order bytes)	
0056	Arc radius r (4-byte floating number, 2 high-order bytes)		0057	Arc radius r (4-byte floating num Channel-h Hber, 2 low-order bytes)	
0058	Camber Angle (4-byte floating number, 2 high-order bytes)		0059	Camber Angle (4-byte floating num Channel-h Hber, 2 low-order bytes)	
005A	Rect. Channel Width b (4-byte floating number, 2 high-order bytes)		005B	Rect. Channel Width b (4-byte floating num Channel-h Hber, 2 low-order bytes)	

**Operating Instructions for Ultrasonic Open Channel Flowmeter**

	bytes)			Hber, 2 low-order bytes)	
005C	Rect. Channel Channel-h H (4-byte floating number, 2 high-order bytes)		005D	Rect. Channel Channel-h H (4-byte floating num Channel-h Hber, 2 low-order bytes)	
005E	Trapez. Channel Max surface-w B (4-byte floating number, 2 high-order bytes)		005F	Trapez. Channel Max surface-w B (4-byte floating num Channel-h Hber, 2 low-order bytes)	
0060	Trapez. Channe lBottom width b (4-byte floating number, 2 high-order bytes)		0061	Trapez. Channel Bottom width b (4-byte floating num Channel-h Hber, 2 low-order bytes)	
0062	Trapez. Channe Channel-h H (4-byte floating number, 2 high-order bytes)		0063	Trapez. Channel Channel-h H (4-byte floating num Channel-h Hber, 2 low-order bytes)	
0064	Circular radius (4-byte floating number, 2 high-order bytes)		0065	Circular radius (4-byte floating num Channel-h Hber, 2 low-order bytes)	
0066	Para. Channel Max surface-w B(4-byte floating number, 2 high-order bytes)		0067	Para. Channel Max s urface-w B (4-byte floating num Channel-h Hber, 2 low-order bytes)	
0068	Para. Channel Channel-h (4-byte floating number, 2 high-order bytes)		0069	Para. Channel Channel-h (4-byte floating num Channel-h Hber, 2 low-order bytes)	
006A	Reserved		006B	Reserved	
006C	Reserved		006D	Reserved	
006E	Reserved		006F	Reserved	
0070	Roughness n (4-byte floating number, 2 high-order bytes)		0071	Roughness n (4-byte floating num Channel-h Hber, 2 low-order bytes)	
0072	Slope i (4-byte floating number, 2 high-order bytes)		0073	Slope i (4-byte floating num Channel-h Hber, 2 low-order bytes)	
0074	Reserved		0075	Reserved	
0076	Reserved		0077	Reserved	
007A	Reserved		007B	Reserved	
007C	Reserved		007D	Reserved	
007E	Reserved		007F	Reserved	
0080	Alarm 1 mode Alarm 2 mode		0081	Alarm 3 mode Alarm 4 mode	
0082	Measuring Mode Unit Selection		0083	Algorithm Select Safe level	
0084	Transducer Type Damping Rate		0085	Cum. flow reset Flow unit	
0086	Interface switch Current output		0087	Triangle weir Rectangular weir	
0088	Trapezoidal weir Parshall		0089	U-channel Rect. channel	
008A	Trapez. Channel Circular channel		008B	Para. Channel Reserved	
008C	Factory Reset System Reset		008D	Baud Rate Working Mode	
008E	Cum. Unit Angle Setting		008F	Reserved Reserved	
0090	Reserved Reserved		0091	Reserved Reserved	
0092	Reserved		0093	Phenotype character Meter address	

**11.10 Other**

11.10.1 4-byte floating number: it conforms to the single-precision floating number upon IEEE - 754 standard.

Byte address	+3	+2	+1	+0
Floating number	SEEEEEEE	EMMMMMM M	MMMMMMMM	MMMMMMMM

S - sign bit, "1" indicates negative and "0" indicates positive.

E - expoent

M - the decimal part of mantissa

For example: floating number 124.75 = 42F94000H. The storage format in memory is:

Byte address	+3	+2	+1	+0
Floating number	0 100010	1 1111001	01000000	00000000

11.10.2 8-byte double-precision (double type): it conforms to the IEEE—754 standard.

For example: floating number 38414.4 =40E2C1CCCCCCCC H. The storage format in memory is:

Byte address	+7	+6	+5	+4	+3	+2	+1	+0
Floating number	SEEE EEEE	EEE EM MM M	MMMM MMMM	MMMM MMMM	MMMM MMMM	MMMM MMMM	MMMM MMMM	MMM MMM MM

Measuring mode: 0 -- measuring distance; 1 -- measuring material level

Safe level: =0, hold; =55, minimum; =AA, maximum; =A5, set value

Alarm mode 1, 2, 3, 4: 0 -- off; 1 -- low alarm; 2 -- high alarm

Unit selection: = 0, mm; = 1, cm; = 2, m

Algorithm Select: 0 - special environment 1; 1 -- special environment 2;

2 -- special environment 3; 3 -- special environment 4;

4 -- special environment 5; 5 -- special environment 6;

6 -- special environment 7

Transducer Type: 0 -- option 1; 1 -- option 2; 2 -- option 3; 3 -- option 4; 4

-- option 5; 5 -- option 6; 6 -- option 7; 7 -- option 8; 8 --

option 9;

Damping Rate: 0 -- slow; 1, medium speed; 2 - fast;

Cum. flow reset: 0 - No; 1 - Yes;

Flow unit: =0,t/h; =1,l/s; =2,t/s;

Interface switch: 0 - No; 1 - Yes;

Current output: =0, flow output; =1 liquid level output

Triangle weir: =0, not selected; =1, selected

Rectangular weir: =0 not selected; =1, 0.25 m; = 2, 0.50 m; = 3, 0.75 m; =4,

1.00 m; =5, customized

Trapezoidal weir: =0 not selected; =1, selected

Parshall: =0, not selected; =1, selected  
 U-channel: =0, not selected; =1, selected  
 Rect. channel: =0, not selected; =1, selected  
 Trapez. channel: =0, not selected; =1, selected  
 Circular channel: =0, not selected; =1, selected  
 Para. channel: =0, not selected; =1, selected  
 Factory reset: 0-No; 1-Yes;  
 System reset: 0-No; 1-Yes;  
 Baud rate: 0-2400; 1-4800; 2-9600; 3-19200  
 Working mode: 0 -- automatic report mode; 1 -- query mode  
 Cum. unit: =0, m<sup>3</sup>; =1,l  
 Angle Setting: 0—30; 1—45; 2—60; 3—90

### 11.10.3 Regional read-write operation of register

The first region: 0000 — 0021 read only  
 The second region: 0022 — 0073 read-write  
 The third region: 0080 — 0093 read-write

Within the same region, a parameter can be read (or write) at a time, and all parameters in the region can be read (or write) in batch. It is not allowed to read and write parameters cross regions.

11.10.4 All reserved registers are currently undefined, reserved for upgrade compatibility.

### 11.11 Table of Information Code

Information code	Indication
01H	Invalid function code
02H	Invalid data address
03H	Invalid data value
04H	CRC16 verification error
05H	Correct reception
06H	Reception error
07H	Parameter error

### 11.12 Example of Serial Port Data Frame Acquisition Communication Protocols

Data sent by the host

Station number	Function code	Initial address	Point number reading	Check code	Indication
01	03	0000	0002	C40B	Read water level value, single precision floating number

01	03	0002	0002	65CB	Read instantaneous flow value, single precision floating number
01	03	0004	0002	85CA	Read the integral part of the accumulative flow value, long integer
01	03	0006	0002	240A	Read the decimal part of accumulative flow value, single-precision floating number

### 11.13 PLC address setting (Example: Siemens S7-200 PLC)

If there is no function code setting item during the PLC setting, the base address of modbus RTU register corresponding to the function code 03 is 40001.

Therefore, the register address of PLC shall be added with 1 during the register address setting.

For example: The MODBUS register address of ultrasonic open channel flowmeter is 2 (0x0002), and when the MODBUS function code is 3, the PLC register address is 40003.

Reading table of PLC address

Function code: 03

Description: Read and hold register values.

Address	Description	Remark
40001	Instantaneous value of distance/material level	Single-precision floating number
40003	Instantaneous flow rate	Single-precision floating number
40005	Integral part of the cumulative flow value	Long integer
40007	Decimal part of the cumulative flow value	Single-precision floating number
40009	Simulated output instantaneous value	Single-precision floating number
40011	Instantaneous temperature value	Single-precision floating number