

Installation and Operating Instructions



Before operating this unit, please read these instructions completely.

Instructions for Tuning Fork Resonance Density Meter

I. Overview

1. The plug-in density meter adopts plug-in installation and is widely used in pipelines. The density of medium in open tanks and closed tanks is directly determined by the vibration frequency received by the tuning fork of the sensor inserted into the medium. The built-in temperature sensor of the sensor provides temperature compensation for it.
2. Scope of application: The plug-in density meter can perform density detection online in real time. It can be used for process control of products with density as the basic parameter or quality control with solid percentage or concentration percentage as a reference. Typical industries include petrochemical industry, wine industry, food industry, pharmaceutical industry and mineral processing (such as clay, carbonate, silicate, etc.), which are specifically used in the interface detection and mixing of multi-product pipelines in the above industries. The density detection, the end-point monitoring of the reactor, and the interface detection of the separator. The sensor works based on the principle of component vibration, and the component part is the part of the tuning fork immersed in the measured liquid. The tuning fork part induces vibration through an internal piezoelectric device fixed at the bottom end of the fork body. The oscillation frequency is detected by a secondary piezoelectric device fixed at the other end of the fork body, and then the signal is amplified by the circuit on the top. The density of the liquid is closely related to the vibration frequency when the measured liquid flows. When the density of the measured liquid changes, the vibration frequency when the liquid flows also changes. Through the following equation, the density of the measured liquid can be accurately calculated.

$$D = K_0 + K_1T + K_2T^2$$

D= Uncalibrated density of the measured medium (kg/m³)
T= Vibration frequency (μs). K₀, K₁, K₂= constant

In the process of density detection, APX301 plug-in density meter can automatically compensate for the influence of temperature on the density (D) of the measured medium, and pressure has no significant influence on density.

Parameter characteristics:

Measuring range	0 - 2.5 g /cc (0 - 2500 kg/m ³), 0~100.0%
Calibration range	0 - 2.5 g /cc (0 - 2500 kg/m ³), 0~100.0%
measurement accuracy	± 0.001 g /cc (± 1 kg/m ³) , ±0.5%
Repeatability	± 0.001 g /cc (± 0.1 kg/m ³) ±0.1%
Medium temperature range	-50°C ~ +150°C
Working pressure	4mpa
Fluid viscosity range	0 - 600 cP
Temperature Coefficient	< 0.1 kg/m ³ /°C (±0.5%) After correction
Stress effect	Negligible
Built-in temperature sensor	Digital sensor
Wetted material	316L、2205 Stainless steel、哈 C、Titanium alloy
Fork body coating	Standard PTFE or PFA
Power supply	24VDC, ≥50 mA
Analog signal output	4 -20 mA, 0-1000Hz, RS485 Modbus RTU HART
Output accuracy (20°C)	± 0.1% of reading or ± 0.05% FS
Output repeatability (-40 ~ +85°C)	± 0.05% FS
Process connection	DN50PN16
	G1.5" thread or 3" hygienic chuck
Protection level	IP67
shell	Aluminum alloy

2. Mechanical installation

Unlike the pipe density sensor, the fork part of the plug-in density meter is not completely enclosed.

1. Pipe wall or container

The boundary effect of the wall on the fluid plus the viscosity effect of the measuring medium itself, these effects will have a certain influence on the measurement calibration of the sensor.

In order to overcome these, for different environments, we summarized and set the installation method and pipe diameter in advance to facilitate the selection under the same conditions.

Installation standard	T-shaped side opening plug-in installation	T-shaped side opening retractable installation	
instruction	The fork body directly enters the main fluid	The fork body is retracted into the side of the pipeline to avoid the main fluid, and retracted by 25mm	
Flow rate	The flow rate through the fork is 0-1m/s	The main pipe flow rate is 1-5m/s	
Viscosity range	Max 600Cp	Maximum 100cP (up to 250cP in individual cases)	
temperature	-50-150°C	-50-150°C	
Main pipe size	≥ Horizontal pipeline 100mm (4"); ≥ Vertical pipe 150mm (4");	≥50mm (2")	
shortcoming	Not applicable to: 1. Unstable flow rate 2. The main pipe diameter is less than DN100	1.	Flocculent solution (such as pulp, etc.)
		2.	Unstable flow rate
		3.	Solutions with tapered viscosity
		4.	The main pipe diameter is less than DN50
		5.	Cases where the temperature effect is significant

2. Calculation of flow rate

$$V = Q / (1/4 * \pi * d^2) \quad \text{Example: Flow rate 20m}^3/\text{h, pipe diameter 100mm}$$

$$V = 20 / 3600 / (1/4 * 3.14 * 0.1 * 0.1) = 0.7 \text{ M/s}$$

3. Installation location

In order to ensure that the density meter can measure accurately and display stability, the flow rate of the measured medium must not be greater than 1m/s, and the diameter of the pipeline where the density meter is installed must be greater than or equal to 159mm. The location of the density meter should be installed as far away as possible from the pump, and the distance should preferably be greater than 5m; When the flow rate is greater than 1 m/s, use the expanded diameter installation. When the flow rate increases by 1m, the pipe diameter of the density meter is increased by 1.5 times. There must be a straight pipe section ≥ 600mm before the instrument and a straight pipe section ≥ 300mm behind the instrument. The fluid is in a laminar state when flowing through the fork body,

As shown in the figure: horizontal installation of horizontal pipeline

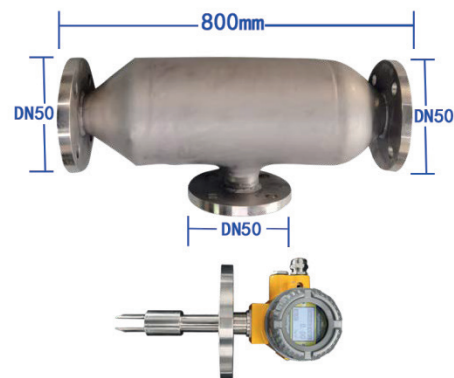
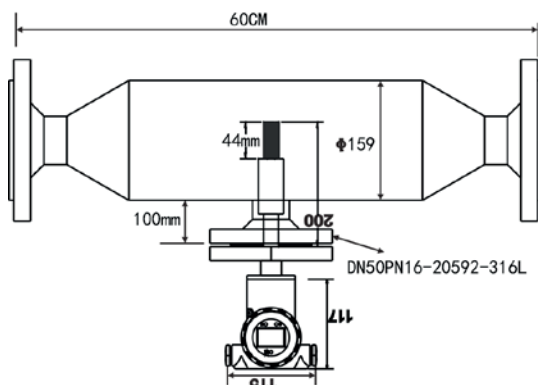

Concentric reducer vertical pipe
Insert directly into the fluid

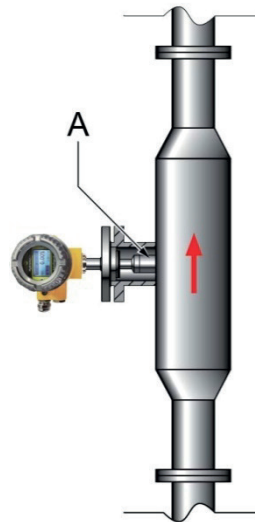

Concentric reducer horizontal pipe
Horizontal pipe top view

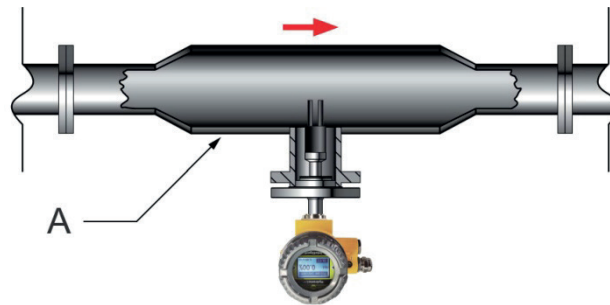

Eccentric reducer horizontal pipe

- A. Side view of horizontal pipeline (the instrument is on the opposite side)
- B. Eccentric pipe expanding device/reducing pipe
- C. The instrument is inserted into the fluid in the expansion device
- D. Internal view of piping and instrumentation

If an eccentric reducer is used, the pipe must maintain a 20-inch (500 mm) upstream straight section (two sides for two-way fluid applications) to avoid jet effects and comprehensive "jets" on the tines of the tuning fork.

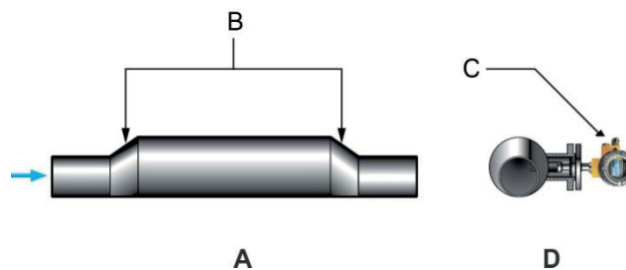

During the installation process, always keep the gap between the tines in the vertical direction when positioning the instrument, which facilitates the settlement of solids and the rise of gas



Figure 2-5: Free fluid (welded base) meter installation

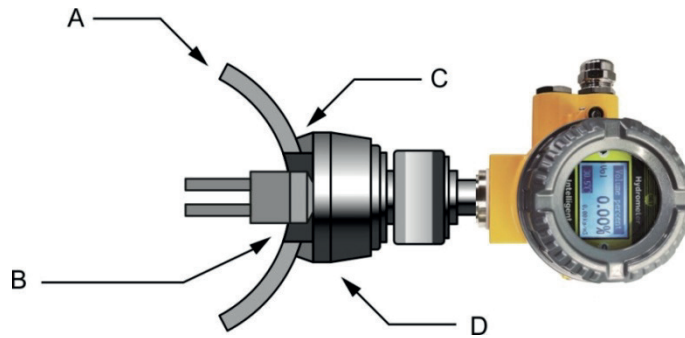

- A. Horizontal installation is a 4-inch pipe; vertical installation is a 6-inch (152 mm) pipe
- B. 2.1 inch (52.5 mm) meter opening on the pipe
- C. Welding
- D. Free fluid welding base (purchase according to pipe diameter)

T-pipe installation

Instrument T-sleeve (flange joint) installation

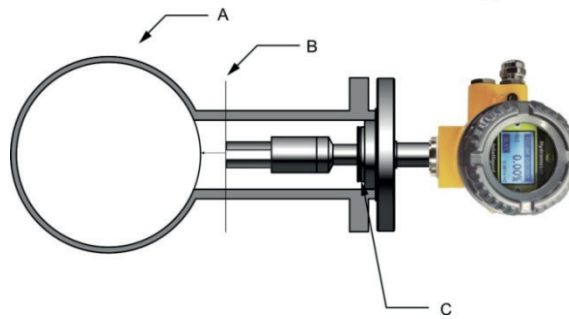

- A. Horizontal or vertical installation of pipes with 4 inches or larger diameter
- B. The distance between the instrument tuning fork and the main pipe wall is determined by the maximum flow rate of the process.
- C. PFA washer and compression spring (not needed for self-locking PFA washer)

For vertical and horizontal pipes, always install the instrument on the side of the pipe. For horizontal pipelines, it is forbidden to install meters on the top of the pipeline.

Pipe wall installation

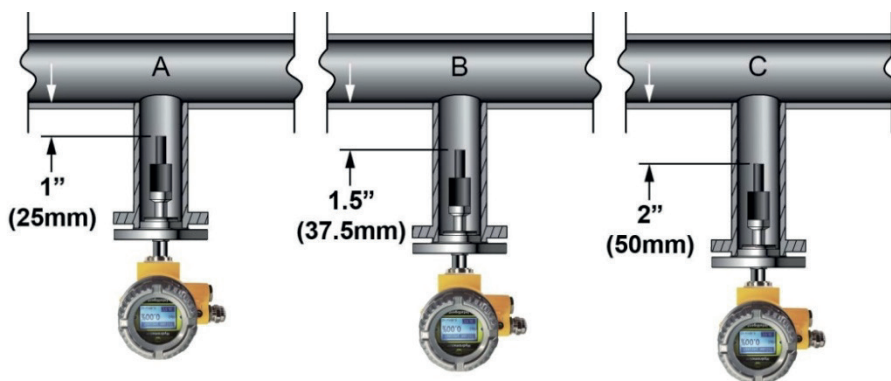

- A. Velocity \leq 10 feet/second (3 meters/second)

B. $10 < \text{Velocity} \leq 13$ feet/second (4 meters/second)

C. $13 < \text{Velocity} \leq 16$ feet/second (5 meters/second)

3-inch T-sleeve installation:

For slurry measurement applications, it is installed in T-sleeve pipes. The T-sleeve should be 3 inches (76 mm) (DN80) and installed diagonally to ensure self-draining. Flow rates as low as 1.0 m/sec are acceptable, and the preferred flow rate is 3 m/sec. Care should be taken when the flow velocity is 5 m/s, as it will increase the risk of blockage of the T-shaped casing. May require additional cleaning.

Flow rate 0.5 to 5 m/s (at the pipe wall)

Viscosity up to 100 cP, 250 cP under some conditions

Temperature — -58°F to 392°F (-50°C to 200°C)

— -40°F to 392°F (-40°C to 200°C) (hazardous area)

Horizontal pipe

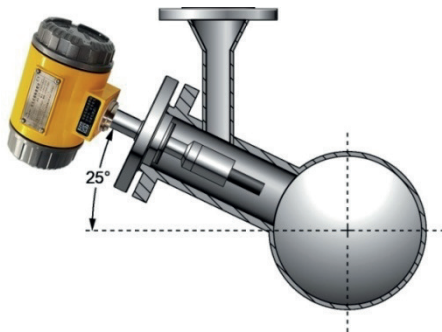

Vertical pipe

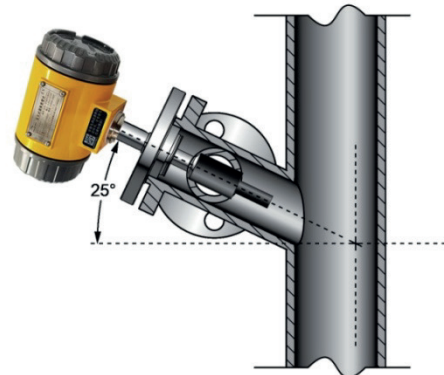

Instrument installation for open tanks (long pole)

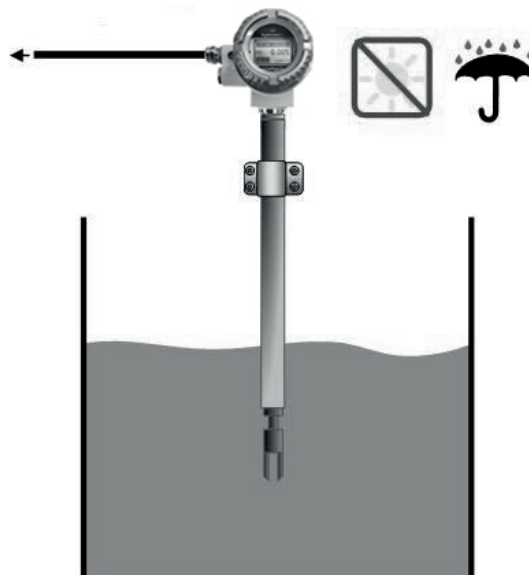

Instrument placement (away from the tank wall)

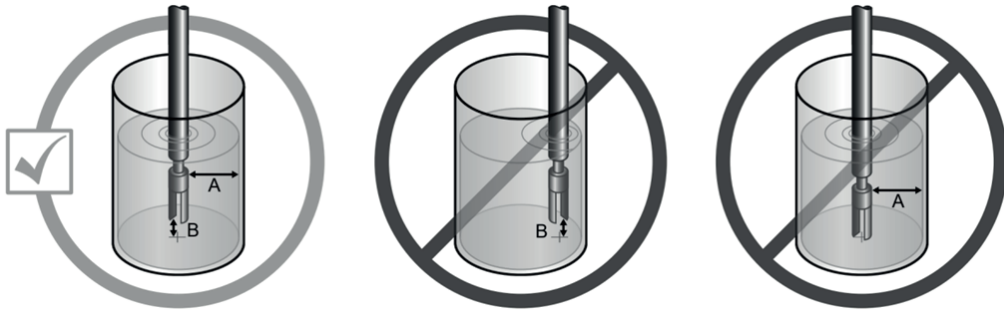

Instrument placement (distance to objects and turbulence)

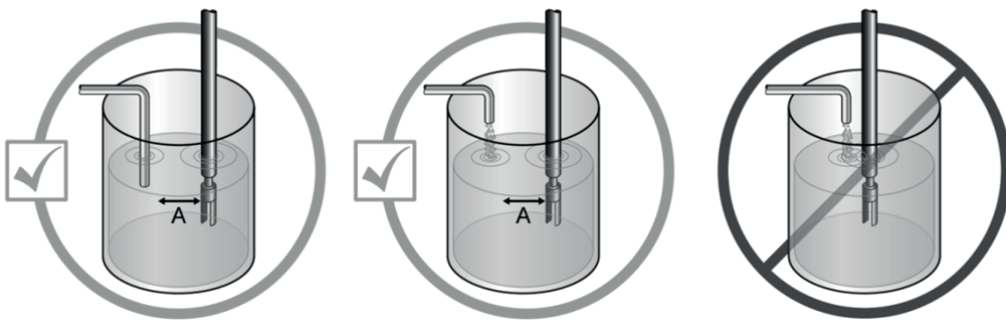

Instrument placement (fluid direction through the tuning fork gap)

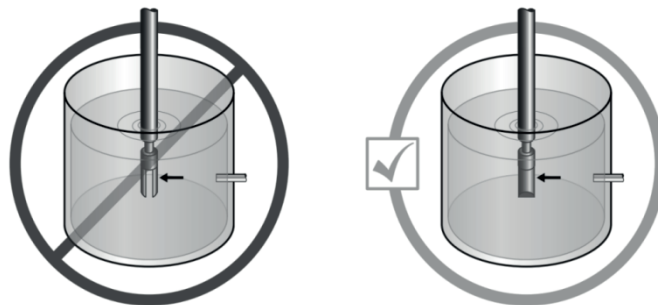

Instrument placement (away from deposits)

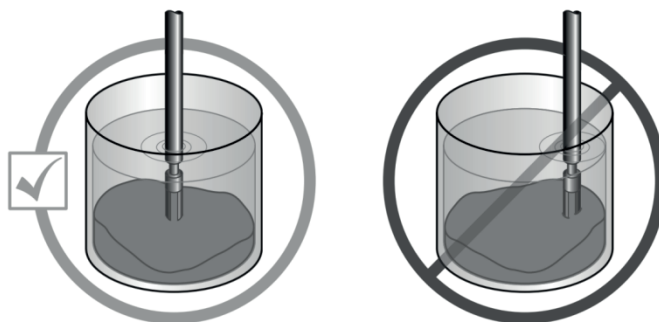

Schematic diagram of horizontal installation of density meter pipeline

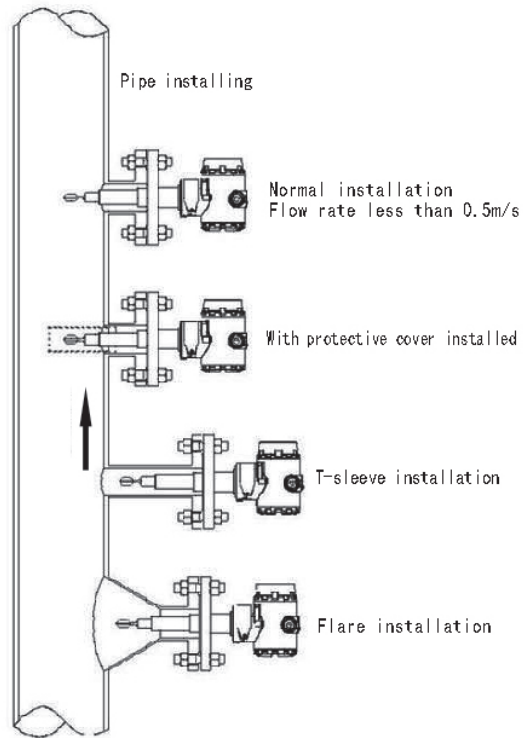

Vertical Pipeline Installation Dimensions (1)

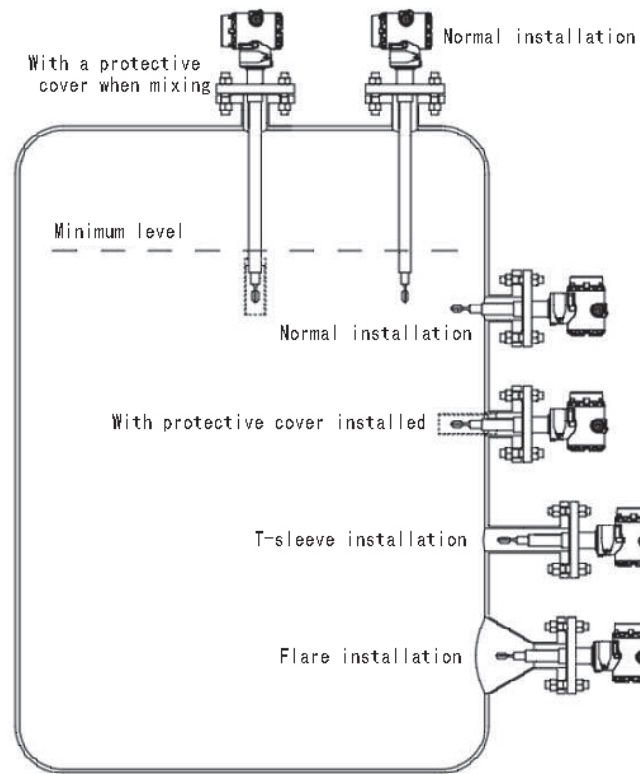

Unreasonable installation diagram

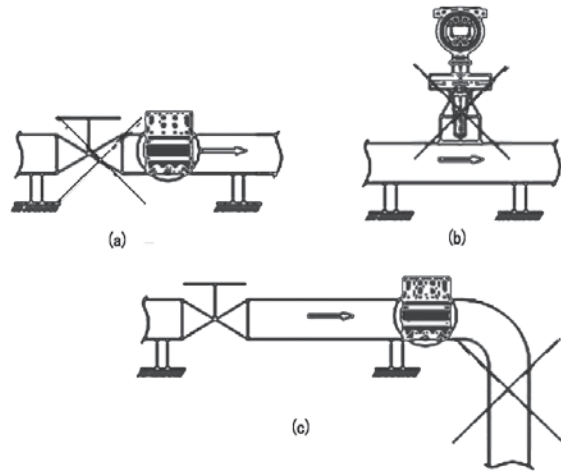

Schematic diagram of unreasonable installation of horizontal pipeline

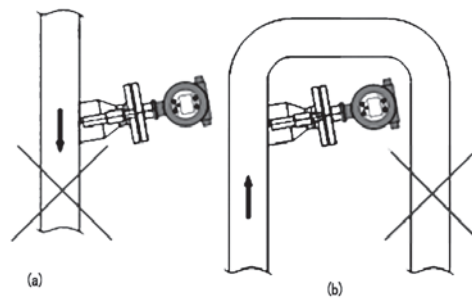

Schematic diagram of unreasonable installation of vertical pipelines

3. Electrical wiring diagram

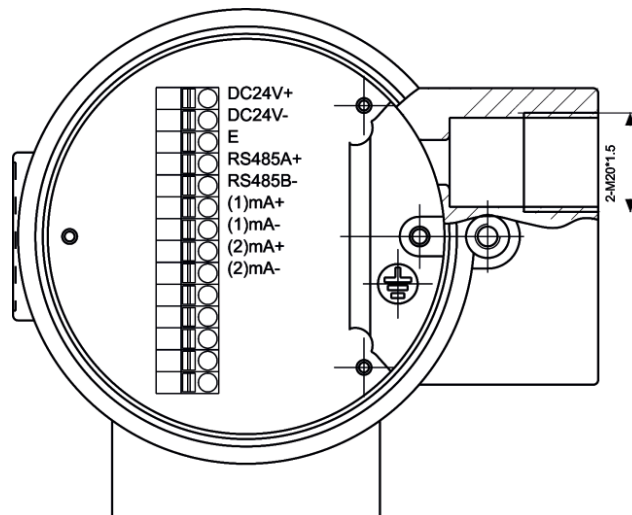

Support two-wire, three-wire, four-wire

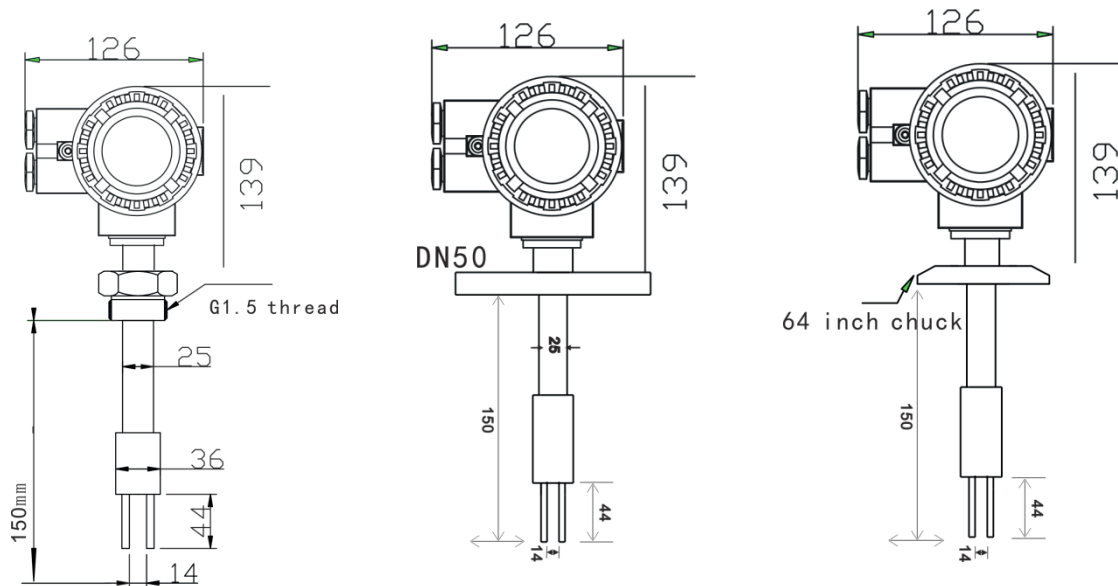

Dimensional structure diagram of spraying tetrafluoro density meter

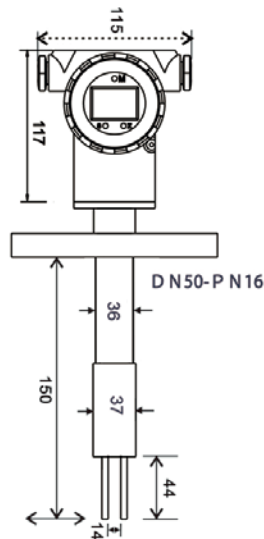

4. Calibration and Operation

Before calibrating the meter make sure it has been installed.

Through the buttons on the instrument panel, you can adjust the zero point, span, setting unit, zero point shift, span shift, damping, output characteristics, and change the display output.

1. Button function description

SET—Setting and returning to save and exit when the operation is completed

 — Revise

 — Shift

 — confirm

2. Parameter setting

Parameters such as range, composition, damping time, unit, installation pipeline, etc. can be modified through parameter settings.

After pressing the **OK** key, the menu interface appears, the arrow **▶** points to "parameter setting", press **◀** to move **▶** to other settings, select "parameter setting" and then press **OK** to enter the parameter setting interface "range upper limit", again Press **OK**, an underline appears below the upper limit value, indicating that this digit can be modified, press **↑** to modify the value of the current digit, continue to press **◀** to shift to the digit that needs to be modified, and press **↑** to modify, and press again after the modification is completed. The underline of **OK** key disappears and the modification is completed. At this time, continue to press **◀** to display in sequence → lower limit of range → component A → component B → damping time → unit → installation pipeline → interface, use the same operation method to set the above parameters, and press "SET" Exit the current interface and go to the setting interface number 10 (the interface number will be displayed in the upper right corner of the display).

3. Display settings

The display content of the main variable and the effect of the screen display can be changed by setting

Press the **OK** key to appear the menu interface, the arrow **▶** points to "parameter settings", press **◀** to move **▶** point to "display settings", then press **OK** to enter the display settings interface", press **OK** again to appear **▶** point to the display content Option, press **◀** to move **▶** point to the desired display content and press **OK** to complete the setting, if you do not need to save the settings, press "SET" before pressing **OK** to exit the previous level, continue to press **◀** to display → contrast → backlight → Language → Use the same operation method to set the above parameters, press "SET" to exit the current interface and go to the setting interface No. 10.

4. Output settings

Through the output setting, the corresponding mode of the output signal can be matched. This product supports two output modes: 4-20mA and RS485 (MODBUS protocol). You can choose one of the parameters of density, temperature and percentage to output the current signal.

RS485 can output all signals.

After pressing the **OK** key, the menu interface appears, the arrow **▶** points to "parameter setting", press **◀** to move **▶** point to "output setting", then press **OK** to enter the output setting interface", press **OK** again to appear **▶** point to the setting content Option, press **◀** to move **▶** point to the desired setting content and press **OK** to complete the setting, if you do not need to save the settings, press "SET" before pressing **OK** to exit the previous level, continue to press **◀** to display the content in turn → 2 (4-20mA) → RS485/BPS → Address 1-254 → Relay → Set the above parameters with the same operation method, press "SET" to exit the current interface and go to the setting interface No. 10.

The above 2(4-20mA) and relay are the selection configuration, this function is not a general configuration.

5. RS485 communication

1. Communication baud rate and address change

After pressing the **OK** key, the menu interface will appear, and the arrow points to "parameter setting". Press **←** to point the arrow to "output setting" and press the **OK** key to enter the output debugging interface. The arrow points to the baud rate in the down **↓** key, press **OK** to select the baud rate, select the corresponding baud rate and press the **←** key again to complete the setting.

After the setting is completed, the arrow disappears. Press **←** again to display the "Address 1~254" interface. Press **OK** to display the underline value, indicating that it can be changed. Press **←** to move the underline and the corresponding bit can be modified. Press **↑** to change the value. After the change is completed, press **OK** to complete the operation and press "SET" to exit the setting interface and enter the main interface display.

2. Description of RS485MODBUS communication protocol

1. Function code 03

Use the 03 function code of the MODBUS communication protocol to read the value of the sensor or display (1 value). The command format of the host is slave address, function code, start address, number of bytes and CRC code. The command format of slave response is slave address, function code, data area and CRC code. The data in the data area is a binary code, two bytes, with the high order first, and the CRC code is two bytes, with the low order first.

2. Information frame format: (slave address is 01, both are binary data)

Host sends:

Station number (1B) Function code (1B) Start address (2B) Number of read points (2B) CRC (2B)
 T1~T4 01 03 00 0X 00 0X XX XX T1~T4

Among them: T1~T4 means that 3~5 static periods should be reserved at the beginning and end of each frame:

Station number (address): one byte "01"

Function code: one byte "03"

Start address: two bytes: 0000~0004 is optional

0000, returns the current density value, the unit is kg/cm³;

0001, return the current temperature value, the unit is °C When the temperature is lower than 0 °C, the temperature data is uploaded in the form of complement code FF9BH=-101=-10.1°C;

0002, Returns the current concentration value, the unit is % (10000/100 100.00%);

Number of read points: two bytes: 0001 or 0002 ~0005 is optional

CRC: Validation code. two bytes;

The slave responds:

Station number (1B) Function code (1B) Number of bytes read (1B) Data (2B) CRC (2B)
 T1~T4 01 03 02 XX XX XX XX T1~T4

Among them: T1~T4 means that 4 still periods should be reserved at the beginning and end of each frame (you can customize the editing);

Station number (address): one byte "01"

Function code: one byte "03"

Data: two bytes; the high byte is first, forming 16-bit binary data;

CRC: verification code, two bytes;

3. Calculation rules of CRC code;



- 3.1. Reserve 16-bit registers as hexadecimal FFFF (that is, all 1s). Call this register bit CRC register;
- 3.2. XOR the first 8-bit data with the 16-bit CRC register, and put the result in the CRC register;
- 3.3. Check whether the lowest bit is 0. If it is 0, move the contents of the register one bit to the right (toward the low bit), and fill the high bit with 0;
If it is 1, shift the contents of the register one bit to the right (toward the lower bit), fill the upper bit with 0, and then XOR the CRC register with the polynomial A001 (1010 0000 0000 0001);
- 3.4. Repeat step 3 until the right shift 8 times, so that the entire 8-bit data is processed;
- 3.5. Repeat steps 2 to 4 to process the next 8-bit data;
- 3.6. The final CRC register is the CRC code. When putting the CRC result into the information frame, the high bits are exchanged, and the low bits come first.

4. Example of communication protocol:

Host sends data:

Station	function code	starting address	number of bytes	verification code	significance
01	03	0000	0002	C40B	Read density in kg/m ³
01	03	0002	0001	25CA	read temperature, unit °C
01	03	0003	0001	740A	Read concentration, unit %
01	03	0005	0002	4509	Read the upper limit of the range unit kg/m ³
01	03	0006	0002	E409	Read the lower limit of the range unit kg/m ³
01	03	0007	0002	0408	Read component A in kg/m ³
01	03	0008	0002	A5C8	Read component B in kg/m ³
01	03	0009	0001	85CF	Read damping time in seconds
01	03	000A	0001	D40F	read unit 1-g/L 2-g/ml 3-kg/m ³ 4-g/cm ³

Our Certificates

**DECLARATION OF CONFORMITY
UYGUNLUK BEYANI**

**DECLARATION HOLDER
(DEVİS SAHİBİ)**
PİKSEL ÖLÇÜ AKIŞKAN KONTROL OTOMASYON
SİS. SAN. VE TİC. LTD. ŞTİ.

**ADDRESS
(ADRES)**
MERİÇ MAH. 5746/3 SK. NO:22 BORNOVA İZMİR

**MANUFACTURERS
(DÜZETİCİ)**
PİKSEL ÖLÇÜ AKIŞKAN KONTROL OTOMASYON
SİS. SAN. VE TİC. LTD. ŞTİ.

**PRODUCT
(ÜRÜN)**
ELECTROMAGNETIC COMPATIBILITY
ELEKTROMANYETİK DEBİTME

**TRADEMARK
(MARKA)**
PIKSEL

**TYPE/MODEL
(TİP/MODEL)**
PKS-ED / PKS-ED-PS / PKS-ED-GD / PKS-ID-PSL / PKS-ED-RT

**BASE OF ATTESTATION
(DAYANAK)**
FILE OF TECHNICAL DOCUMENTATION TEST REPORT

**APPLIED EC DIRECTIVES
(UYGULANAN A. T. YÖNETMELİKLERİ)**
2014/30/EU ELECTROMAGNETIC COMPATIBILITY DIRECTIVE
2014/30/EU LOW VOLTAGE DIRECTIVE

**APPLIED STANDARDS
(UYGULANAN STANDARTLAR)**
TS EN 55022 EN 55022, TS EN 55035 EN 55035,
TS EN 60335-1

**LAST TWO DIGIT YEAR OF
CERTIFICATION (Y)**
CE MARK AFFIXED 23
CE İZAHATI YARILMAMIŞTUR 23

We "PİKSEL ÖLÇÜ AKIŞKAN KONTROL OTOMASYON SİSTEMİ SAN. VE TİC. LTD. ŞTİ." have by declare that specified above conditions, operating European Parliament and Council Directive 2014/30/EU Electromagnetic Compatibility Directive and 2014/30/EU Low Voltage Directive.

Ben "PİKSEL ÖLÇÜ AKIŞKAN KONTROL OTOMASYON SİSTEMİ SAN. VE TİC. LTD. ŞTİ." olarak yukarıda belirtilen şartları taşıyan Ürünlerimi 2014/30/EU ELEKTROMANYETİK UYUMLUKLUK DİREKTİFİNE ve 2014/30/EU Aşağı Gerilim Direktifine uygun olduğunu beyan ederim.

İZMİR TÜRKiYE **SİME SÖLME**
Date: 05.12.2023 **GENEL MÜDÜR / GENERAL MANAGER**

DİCA / SIGNATURE

www.pikselotomasyon.com

DECLARATION OF CONFORMITY



**T.C.
TÜRK PATENT VE MARKA KURUMU
MARKA TESCİL BELGESİ**

Marka No : 2020 16838 - Ticaret - Hizmet



Marka Sahibi : GENEL MÜDÜR / GENEL MÜDÜR
TARİHİ : 11.10.2020
Emtiası : 09_35
İlişkiler:

**İşbu Marka 11/02/2020 tarihinde ihbarca ON YIL süreyle
17/10/2020 tarihinde tescil edilmiştir.**



TURK PATENT



SERTİFİKA

**PİKSEL ÖLÇÜ AKIŞKAN KONTROL OTOMASYON
SİSTEMLERİ SANAYİ VE TİCARET LİMİTED
ŞİRKETİ**

MERİÇ MAH. 5746/3 SK. NO:22/2 BORNOVA İZMİR

ISO 9001:2015

**SICAKLIK, BASINÇ, SEVİYE, AKIŞ ÖLÇÜM EKİPMANLARI İMALATI, SATIŞ VE BAKIM ONARIM
HİZMETLERİ**

TRB ULUSLARARASI BELGELENDİRME TEKNİK KONTROL DÜZENLEME HİZMETLERİ LTD. ŞTİ.
Etiler Mah. Katip Mustafa Paşa 06/06 Beşiktaş İlçe Kurumları Binası Kat: 10/10
No: 0102 002 07 00. Fax: 0102 002 07 01. E-mail: info@trb.com.tr web: www.trb.com.tr



CERTIFICATE

**PİKSEL ÖLÇÜ AKIŞKAN
KONTROL OTOMASYON SİSTEMLERİ
SANAYİ VE TİCARET LİMİTED ŞİRKETİ**

MERİÇ MAH. 5746/3 SK. NO:22 B. KAP. NO:2
BORNOVA / İZMİR / TÜRKİYE

Has been assessed and found to comply with the requirements of
Dönüşümlü ve sürdürülebilirlik standartları gerektirilen işletme faaliyetleri.

ISO 14001:2015

The Environmental Management System is applicable to
Çevre Yönetim Sistemi:

**MANUFACTURING, SALES AND MAINTENANCE AND REPAIR SERVICES OF
TEMPERATURE, PRESSURE, LEVEL, FLOW MEASUREMENT EQUIPMENT**

**SICAKLIK, BASINÇ, SEVİYE, AKIŞ ÖLÇÜM EKİPMANLARI İMALATI,
SATIŞ VE BAKIM ONARIM HİZMETLERİ**

Certificate Number: EMS401402 Initial Certification Date: 04.12.2023
Belge Numarası: EMS401402 İlk Belgelendirme Tarihi: 04.12.2023

Certification Period: 3 Years Certificate Validity Date: 03.12.2024
Belgelendirme Periyodu: 3 Yıl Belge Geçerlilik Tarihi: 03.12.2024



IQR ULUSLARARASI BELGELENDİRME HİZMETLERİ LTD. ŞTİ.
Etiler Mah. Katip Mustafa Paşa 06/06 Beşiktaş İlçe Kurumları Binası Kat: 10/10
No: 0102 002 07 00. Fax: 0102 002 07 01. E-mail: info@trb.com.tr web: www.trb.com.tr



CERTIFICATE

**PİKSEL ÖLÇÜ AKIŞKAN
KONTROL OTOMASYON SİSTEMLERİ
SANAYİ VE TİCARET LİMİTED ŞİRKETİ**

MERİÇ MAH. 5746/3 SK. NO:22 B. KAP. NO:2
BORNOVA / İZMİR / TÜRKİYE

Has been assessed and found to comply with the requirements of
Dönüşümlü ve sürdürülebilirlik standartları gerektirilen işletme faaliyetleri.

ISO 45001:2018

The Occupational Health and Safety Management System is applicable to
İş Sağlığı Ve Güvenliği Yönetim Sistemi:

**MANUFACTURING, SALES AND MAINTENANCE AND REPAIR SERVICES OF
TEMPERATURE, PRESSURE, LEVEL, FLOW MEASUREMENT EQUIPMENT**

**SICAKLIK, BASINÇ, SEVİYE, AKIŞ ÖLÇÜM EKİPMANLARI İMALATI,
SATIŞ VE BAKIM ONARIM HİZMETLERİ**

Certificate Number: OHS401402 Initial Certification Date: 04.12.2023
Belge Numarası: OHS401402 İlk Belgelendirme Tarihi: 04.12.2023

Certification Period: 3 Years Certificate Validity Date: 03.12.2024
Belgelendirme Periyodu: 3 Yıl Belge Geçerlilik Tarihi: 03.12.2024



IQR ULUSLARARASI BELGELENDİRME HİZMETLERİ LTD. ŞTİ.
Etiler Mah. Katip Mustafa Paşa 06/06 Beşiktaş İlçe Kurumları Binası Kat: 10/10
No: 0102 002 07 00. Fax: 0102 002 07 01. E-mail: info@trb.com.tr web: www.trb.com.tr